



USE & CARE MANUAL

24 IN. TOP CONTROL BUILT-IN DISHWASHER
DW24X8BA99 | DW24X8BA00



USE & CARE MANUAL

24 IN. TOP CONTROL BUILT-IN DISHWASHER WITH AUTO OPEN DOOR DRYING, 8 PROGRAMS, THIRD RACK, 49DBA IN STAINLESS STEEL / BLACK

DW24X8BA99

DW24X8BA00

THOR
K I T C H E N[®]



Thank you for choosing THOR KITCHEN. This product has been manufactured by Thor International, 4651 E Airport Drive, Ontario, CA 91761. This manual contains all the information you will need to install / use the product correctly and safely. Please read all the instructions prior using the product, and keep this manual in a secure place for future reference. Do not remove the attached adhesive identification label containing code, model number, manufacturer and other information from the product. This label will be used by the THOR KITCHEN authorized service representative in the event that your product needs servicing.

Nous vous remercions d'avoir choisi THOR KITCHEN. Cet appareil a été fabriqué par Thor International, 4651 E Airport Drive, Ontario, CA 91761. Le présent manuel contient l'intégralité des consignes dont vous aurez besoin pour installer l'appareil correctement et en toute sécurité. Veuillez lire l'intégralité des consignes avant installation de l'appareil, puis conservez le présent manuel en lieu sûr afin de pouvoir vous y référer ultérieurement. Ne pas retirer de l'appareil l'étiquette d'identification adhésive qui contient le code, le numéro de modèle, le nom du fabricant et toutes autres informations. Ladite étiquette sera utilisée par le représentant du service après-vente agréé de THOR KITCHEN au cas où votre appareil nécessiterait réparation ou entretien.

Gracias por elegir a THOR KITCHEN. Este electrodoméstico fue fabricado por Thor International, 4651 E Airport Drive, Ontario, CA 91761. Este manual contiene toda la información que necesitará para instalar y usar el electrodoméstico de manera adecuada y segura. Lea todas las instrucciones antes de instalar el electrodoméstico, y mantenga este manual en un lugar seguro para usarlo como referencia a futuro. No quite la etiqueta de identificación adhesiva que contiene el código, número de modelo, fabricante y otros datos del electrodoméstico. El representante de servicio autorizado por THOR KITCHEN usará esta etiqueta en caso de que su electrodoméstico requiera reparaciones.

TABLE OF CONTENTS

IMPORTANT SAFETY INSTRUCTIONS	2
1.1 Information for safety	2
1.2 Signal words explanation	3
1.3 Intended use	3
APPLIANCE SPECIFICATIONS	4
APPLIANCE DESCRIPTION	4
2.1 Main appliance	4
2.2 Third rack	5
2.3 Upper rack	5
2.4 Lower rack	5
QUICK START GUIDE	6
PREPARING AND LOADING THE APPLIANCE	6
3.1 Cookware materials guide	6
3.2 Rack and basket accessories	7
3.3 Loading the appliance	9
3.4 Suggested loading patterns	10
3.5 Adding detergent	12
3.6 Adding rinse aid	13
3.7 Unloading the appliance	13
OPERATION	14
4.1 Control panel description	14
4.2 Program overview	15
4.3 Starting or resuming a cleaning cycle	18
4.4 Interrupting a cleaning cycle	18
4.5 Changing a program	19
4.6 Canceling a cleaning cycle / Draining	19
CLEANING	19
5.1 General cleaning	19
5.2 Cleaning the interior	20
5.3 Cleaning the filter assembly	20
5.4 Cleaning the spray arms	21
MAINTENANCE	22
6.1 Maintenance guidelines	22
6.2 Preparing for extended absence	22
6.3 Preparing for winter	22
6.4 Purchase replacement parts	22
TROUBLESHOOTING	23
ERROR CODES	26
WARRANTY	26

IMPORTANT SAFETY INSTRUCTIONS

1.1 Information for safety

WARNING: When using your dishwasher, follow basic precautions, including the following:

WARNING Risk of injury!

- Do not use the appliance until it has been completely and properly installed.
- Do not push down on the appliance door when it is open.



WARNING

This appliance contains chemicals known to the State of California to cause cancer and/or reproductive harm, and birth defects or other reproductive harm. For more information go to www.P65Warnings.ca.gov.

- Read all instructions before using the dishwasher.
- Use the dishwasher only for its intended function.
- Use only detergents or wetting agents recommended for use in a dishwasher and keep them out of the reach of children.
- When loading items to be washed:
 - Locate sharp items so that they are not likely to damage the door seal; and
 - Load sharp knives with the handles up to reduce the risk of cut-type injuries.
- Do not wash plastic items unless they are marked “dishwasher safe” or the equivalent. For plastic items not so marked, check the manufacturer’s recommendations.
- Do not touch the heating element during or immediately after use.
- Do not operate your dishwasher unless all enclosure panels are properly in place.
- Do not tamper with controls.
- Do not abuse, sit on, or stand on the door or dish rack of the dishwasher.
- To reduce the risk of injury, do not allow children to play in or on a dishwasher.
- Under certain conditions, hydrogen gas might be produced in a hot-water system that has not been used for two weeks or more. HYDROGEN GAS IS EXPLOSIVE. If the hot-water system has not been used for such a period, before using the dishwasher turn on all hot-water faucets and let the water flow from each for several minutes. This will release any accumulated hydrogen gas. As the gas is flammable, do not smoke or use an open flame during this time.
- Remove the door to the washing compartment when removing an old dishwasher from service or discarding it.
- A child or adult can tip the appliance and be killed.
- Install the mounting bracket to the countertop (see **Installation manual**). Verify the mounting bracket has been properly installed and engaged with the appliance.
- Engage the appliance to the mounting bracket by pushing that appliance all the way into the installation location. Ensure the mounting bracket is re-engaged when the appliance is moved.
- Re-engage the mounting bracket if the appliance is moved. Do not operate the appliance without the mounting bracket in place and engaged.
- See installation instructions for details.
- Failure to do so can result in death to children or adults.

IMPORTANT SAFETY INSTRUCTIONS

To check the installation of the mounting bracket:

1. Remove any items from the appliance.
2. Grasp the top rear edge of the appliance and carefully attempt to tilt it forward.
3. Verify that the mounting bracket is engaged.





Grounding instructions

This appliance must be connected to a grounded metal, permanent wiring system, or an equipment-grounding conductor must be run with the circuit conductors and connected to the equipment-grounding terminal or lead on the appliance.

SAVE THESE INSTRUCTIONS

1.2 Signal words explanation

The following signal words are used in this manual

 DANGER	This signal word indicates a hazardous situation which, if not avoided, will result in death or serious injury.
 WARNING	This signal word indicates a hazardous situation which, if not avoided, could result in death or serious injury.
 CAUTION	This signal word indicates a hazardous situation which, if not avoided, could result in minor or moderate injury.
 CAUTION	This signal word indicates a hazardous situation which, if not avoided, could result in property damage.
 NOTICE	This signal word is a preferred signal word to address tips and practices not related to personal injury.

1.3 Intended use

- This appliance is intended for cleaning dishware, silverware and cookware.
- This appliance is intended for household use only.
- This appliance is intended to be used in dry indoor areas only.
- Only use the appliance as mentioned in this manual. Any other use is considered improper and may result in damage to property or injury to persons.
- Potential injury from improper use.
- The manufacturer or vendor cannot be held liable for damages or injury incurred through improper or incorrect use.

APPLIANCE SPECIFICATIONS

Rated voltage	120 V AC, 60 Hz
Rated power	1200 W, 15 A
IP rating	IPX1
Net weight	82.7 lbs (37.5 kg)
Dimensions (W x D x H)	23 7/8 x 25 1/8 x 33 7/8" (60.4 x 63.8 x 85. cm)

APPLIANCE DESCRIPTION

2.1 Main appliance

Fig. 1

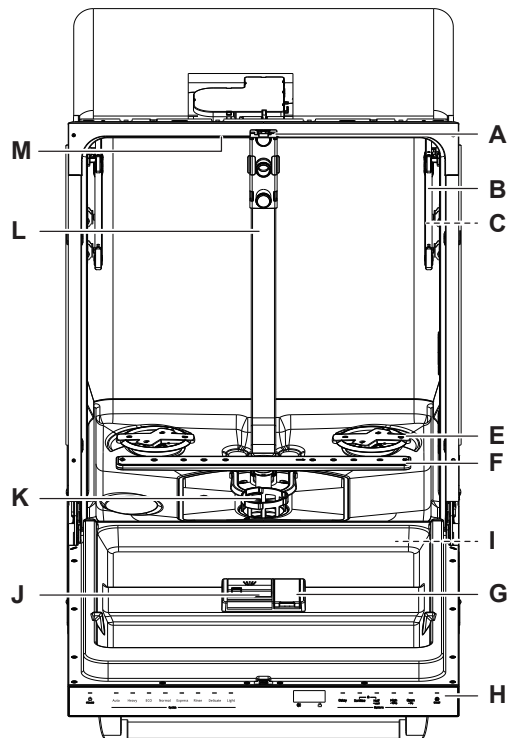

A	Auto open door switch	H	Control panel
B	Third rack sliding bracket x2	I	Spotlight indicator
C	Upper rack sliding bracket x2	J	Detergent dispenser
E	Area wash	K	Filter assembly
F	Lower spray arm	L	Inner pipe
G	Rinse aid dispenser	M	Upper level wash

APPLIANCE DESCRIPTION

2.2 Third rack

Fig. 2

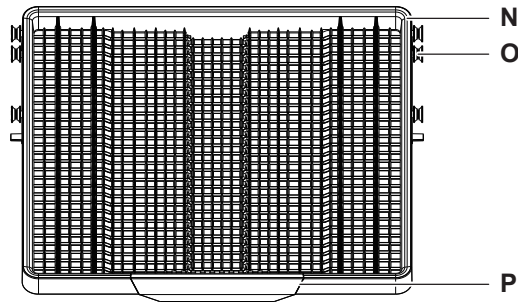

N	Third rack	P	Third rack handle
O	Roller x6		

2.3 Upper rack

Fig. 3

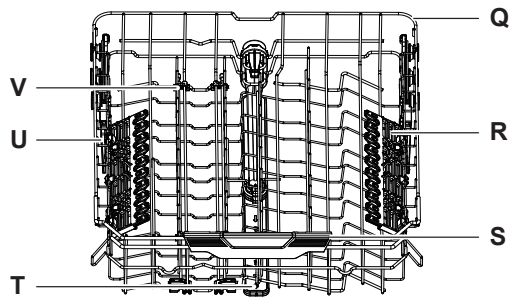

Q	Upper rack	T	Upper spray arm
R	Cup shelf with stemware holder x2	U	Rack height adjuster x2
S	Upper rack handle	V	Folding tines

2.4 Lower rack

Fig. 4

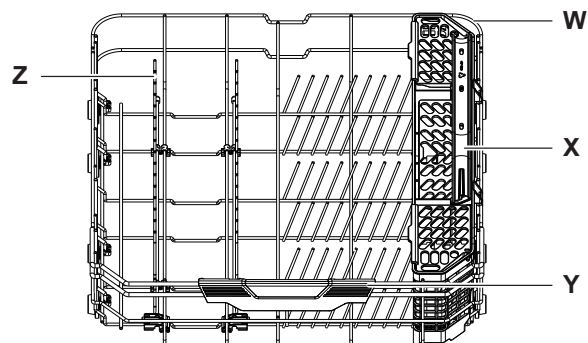

W	Lower rack	Y	Lower rack handle
X	Silverware basket	Z	Sliding tines

QUICK START GUIDE

1. Prepare and load the appliance (Fig. 5).

- Scrape off excess food into the trash or other means of food waste collection.
- Place dishware and cookware so that the water spray reaches all surfaces.

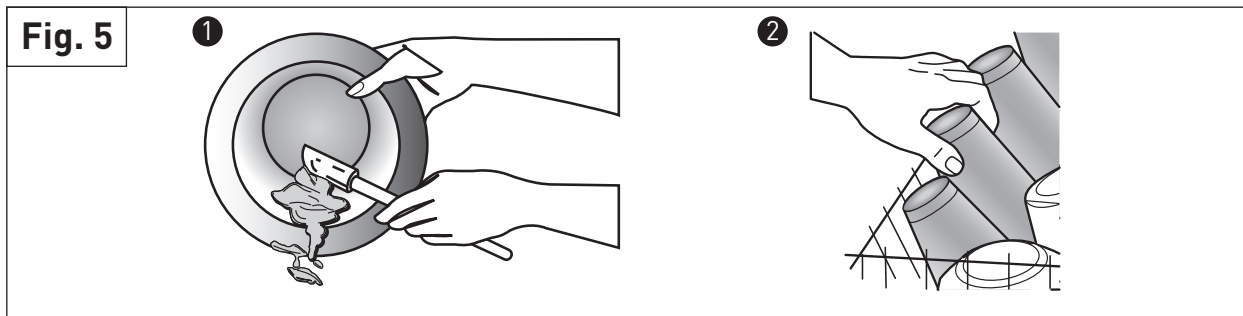

2. Add detergent to the detergent dispenser (J) (Fig. 6).

3. Add rinse aid to the rinse aid dispenser (G) (Fig. 6).

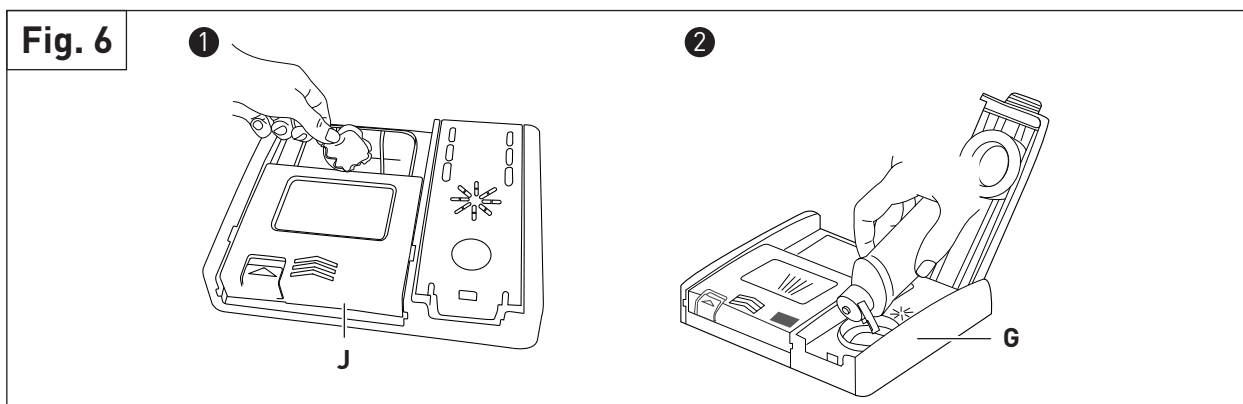

4. Close the door of the appliance securely.

5. Press the **On/Off** button (1) to switch the appliance on.

6. Select a program and desired functions.

7. Press the **Start/Resume** button (18) to start the cleaning cycle.

PREPARING AND LOADING THE APPLIANCE

3.1 Cookware materials guide

NOTICE Do not wash small items that could easily fall out of the racks (N, Q, W) and silverware basket (X) in the appliance.

Unsuitable for the dishwasher

- Wooden, horn china or mother-of-pearl items.
- Plastic items that are not heat-resistant.

PREPARING AND LOADING THE APPLIANCE

- Older items that may have been glued and are not heat-resistant.
- Bonded cutlery items or dishware.
- Pewter or copper items.
- Crystal glassware.
- Hard Anodized cookware.
- Wooden platters.
- Items made from synthetic fibers.

Limited suitability for the dishwasher

- Some types of glassware can become cloudy after several cleaning cycles.
- Silver and aluminum parts may discolor.
- Glazed surfaces may fade.

3.2 Rack and basket accessories

Silverware basket

- Keep silverware separate using the slots in the cover of the silverware basket (X).
- If the silverware does not fit into the designated slots, rotate the covers upward to remove them and mix silverware types to allow more space in between items.
- Load knives down, forks up, and alternate spoons for an optimal clean.

Cup shelves

The upper rack (Q) has cup shelves (R) on each side. Raise the cup shelves (R) to place small cups on top or lean tall glasses against it. Fold it up when it is not needed.

Folding and sliding tines

- The folding tines (V) in the upper rack (Q) are adjustable. Raise them up to make more space for small plates and bowls or lower them to fit more cups and other small items.
- The sliding tines (Z) in the lower rack (W) are adjustable. Slide the tines to the desired position to make more space for bowls, pots or pans (Fig. 7).

PREPARING AND LOADING THE APPLIANCE

Fig. 7

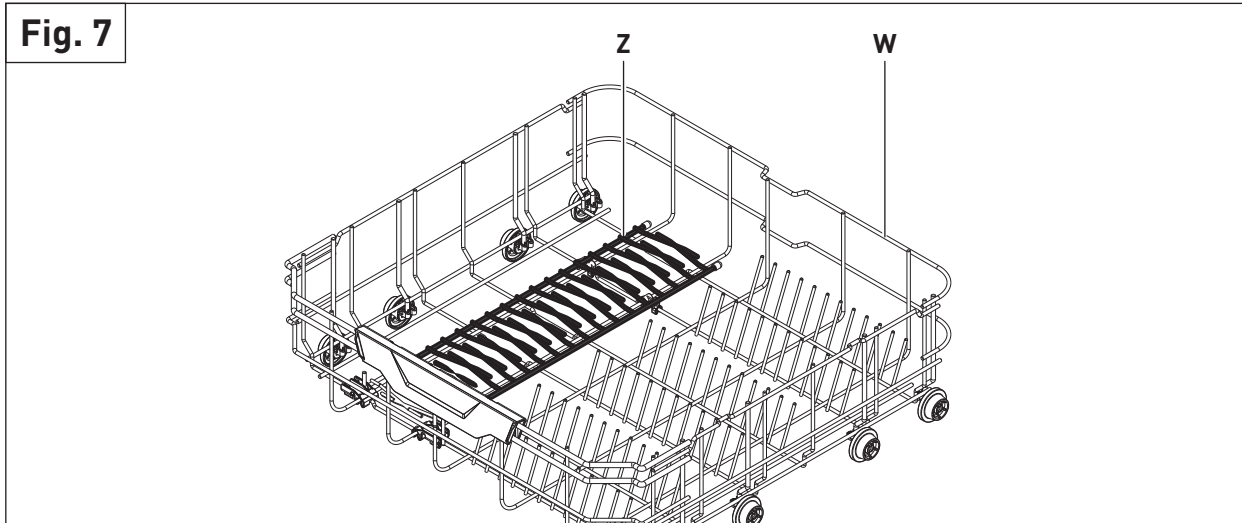

Adjustable upper rack

NOTICE Unload any items from the upper rack (Q) before making adjustments.

The position of the upper rack (Q) can be adjusted to accommodate taller dishware in either the upper rack (Q) or lower rack (W).

To raise the upper rack (Q):

1. Pull the upper rack (Q) out using the upper rack handle (S)
1. Squeeze and hold the rack height adjusters (U) on both sides of the upper rack (Q) (Fig. 8).
2. Pull the upper rack (Q) up until it locks into place at the top position.
3. Release the rack height adjusters (U).

To lower the upper rack (Q):

1. Squeeze and hold the rack height adjusters (U) on both sides of the upper rack (Q) (Fig. 8).
2. Push the upper rack (Q) down until it locks into place at the bottom position.
3. Release the rack height adjusters (U).

PREPARING AND LOADING THE APPLIANCE

Fig. 8

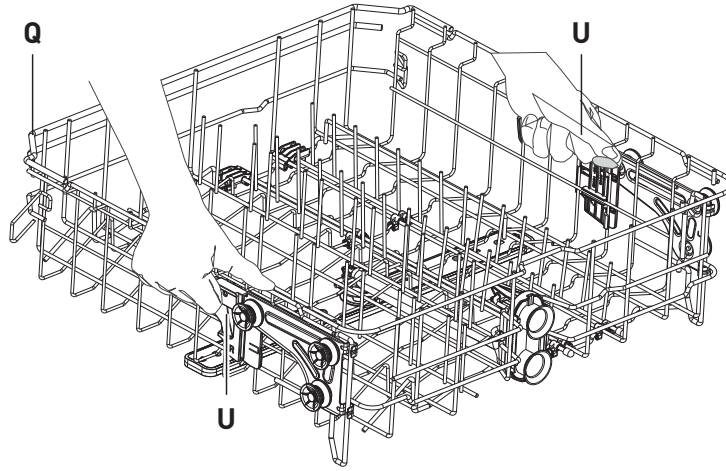

Removable third rack

NOTICE Unload any items from the third rack (N) before removal.

The third rack (N) can be removed to accommodate taller dishware in the upper rack (Q).

To remove the third rack (N):

1. Pull the third rack (N) out using the third rack handle (P).
2. Lift the third rack (N) up and remove it from the third rack sliding brackets (B).
3. Push the rails back into the appliance.

To reinstall the third rack (N):

1. Pull the third rack sliding brackets (B) out on both sides of the appliance.
2. Align and place the wheels of the third rack (N) onto the third rack sliding brackets (B) on both sides of the appliance.
3. Push the third rack (N) into the appliance.

3.3 Loading the appliance

- Scrape off any large amounts of leftover food. It is not necessary to rinse the dishware.
- Soften remnants of burnt food in pans using hot water.
- Load the racks (N, Q, W) and silverware basket (X) from the back to the front and from the bottom to the top. Place large items first, then dishware and cups and finally, silverware.
- Place small items and dishwasher-safe plastic items in the upper rack (Q).
- Place cups, glasses, pots/pans facing downwards.
- Load curved items, or ones with recesses, at an angle so that water can easily slide off.
- Load dishware, utensils and silverware securely to prevent them from tipping over.
- All dishware, utensils and silverware should not block the spray arms (F, T) to allow them to rotate freely during washing.
- Dishware and silverware must not touch or overlap each other.

PREPARING AND LOADING THE APPLIANCE

- Place long and/or sharp cutlery, such as carving knives, in the third rack (N).
- Do not overload the appliance.
- Use the suggested loading patterns for an optimal clean. See chapter 3.4 **Suggested loading patterns**.

3.4 Suggested loading patterns

NOTICE Make sure all items are placed firmly inside the racks (N, Q, W) and silverware basket (X). Items should not extend beyond the bottom of the racks (N, Q, W) and silverware basket (X) to avoid blocking the spray arms (F, T).

Lower rack

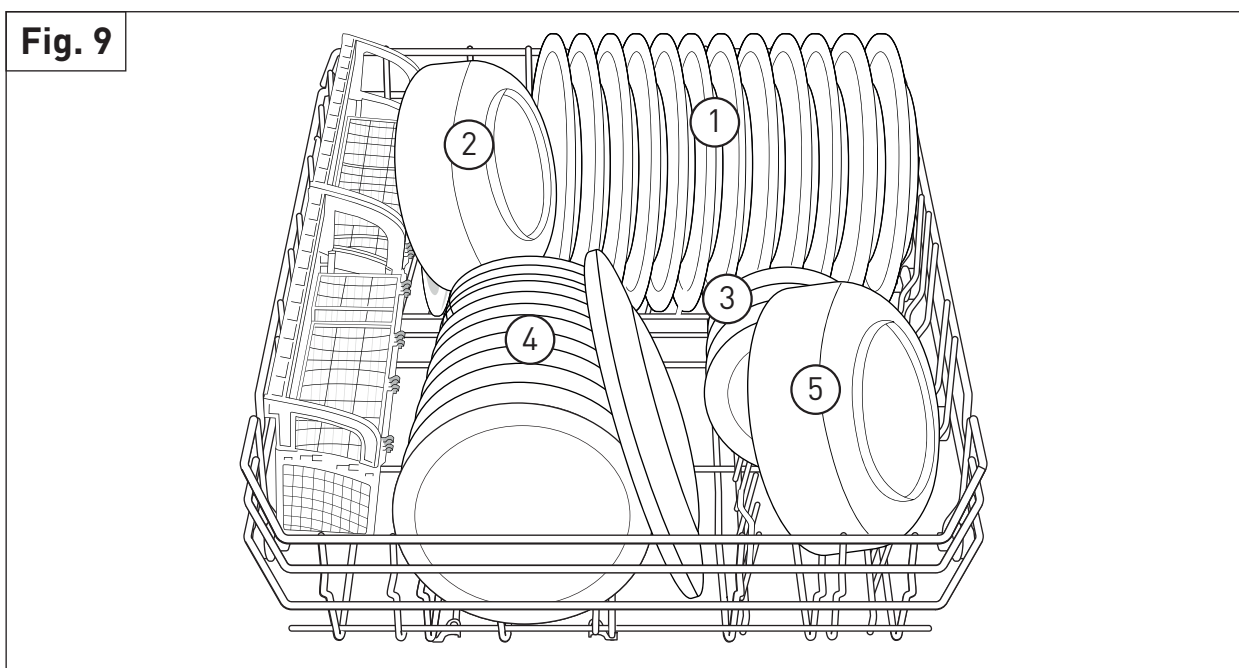

1	Dinner plates	4	Salad plates
2	Serving bowls	5	Soup plates
3	Dessert dishes		

PREPARING AND LOADING THE APPLIANCE

Silverware basket

Fig. 10

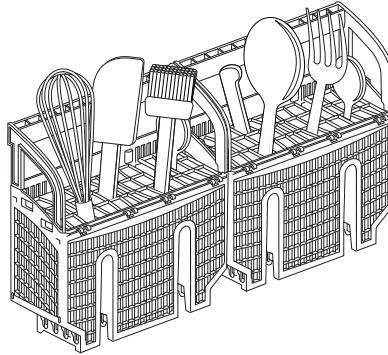

1	Dessert spoons or teaspoons	4	Knives
2	Dessert forks	5	Dinner spoons or serving spoons
3	Salad forks	6	Dinner forks or serving forks

*Utensils listed can be placed in any open slot of the silverware basket

Upper rack

Fig. 11

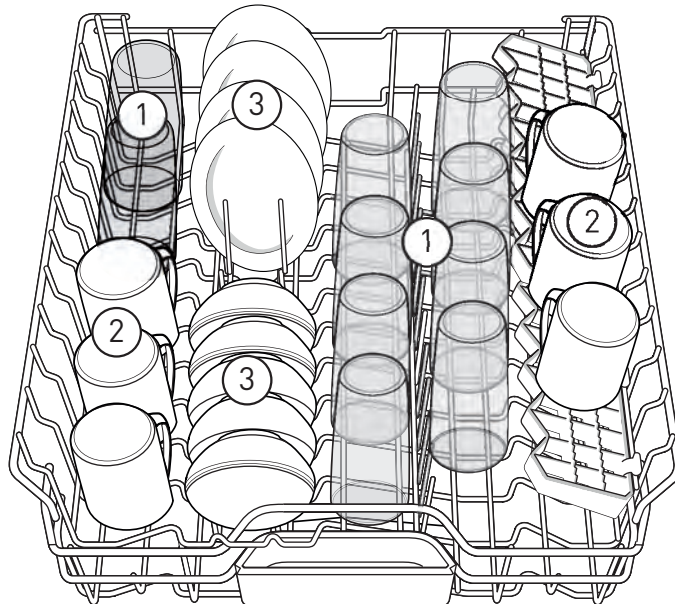

1	Glasses
2	Cups
3	Saucers or small serving bowls

PREPARING AND LOADING THE APPLIANCE

Third rack

Fig. 12

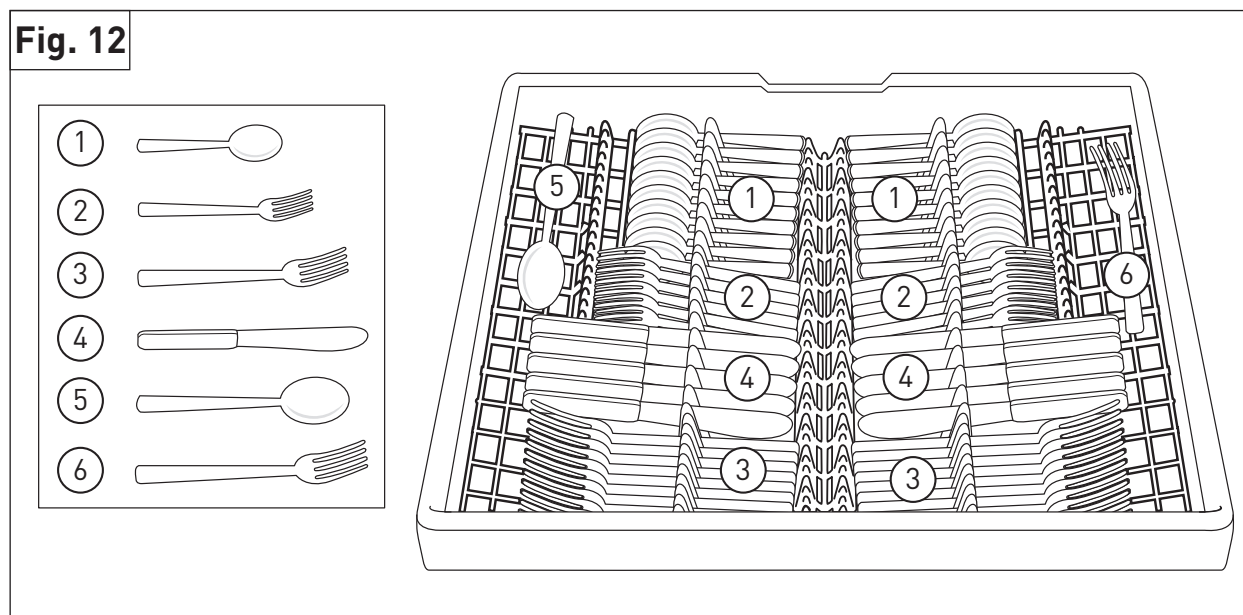

1	Dessert spoons or teaspoons	4	Knives
2	Dessert forks	5	Dinner spoons or serving spoons
3	Salad forks	6	Dinner forks or serving forks

3.5 Adding detergent

Dishwasher detergent contains enzymes that break down the oils and dirt on the dishware and silverware. It should be added every time before starting a cleaning cycle.

NOTICE

- Only use detergent intended for dishwasher use. Gel detergent, powder detergent or single dose tabs can be used.
 - It is recommended to use a water softener if the area has hard water deposits greater than 15 grains/gal.
 - If the water in the area is soft, add less detergent to prevent glassware and delicate items from etching.
 - The strength and cleaning capabilities of dishwasher detergent vary by brand. Refer to the packaging of the detergent for the recommended amount.
 - The capacity of the detergent dispenser (J) is **max. 2 tbsp (30 ml)**.
1. Push the tab of the detergent dispenser (J) lid to open it (Fig. 13).
 2. Add an appropriate amount of detergent to the dispenser (Fig. 13).
 3. Slide the detergent dispenser (J) lid forward until it clicks into place (Fig. 13).

PREPARING AND LOADING THE APPLIANCE

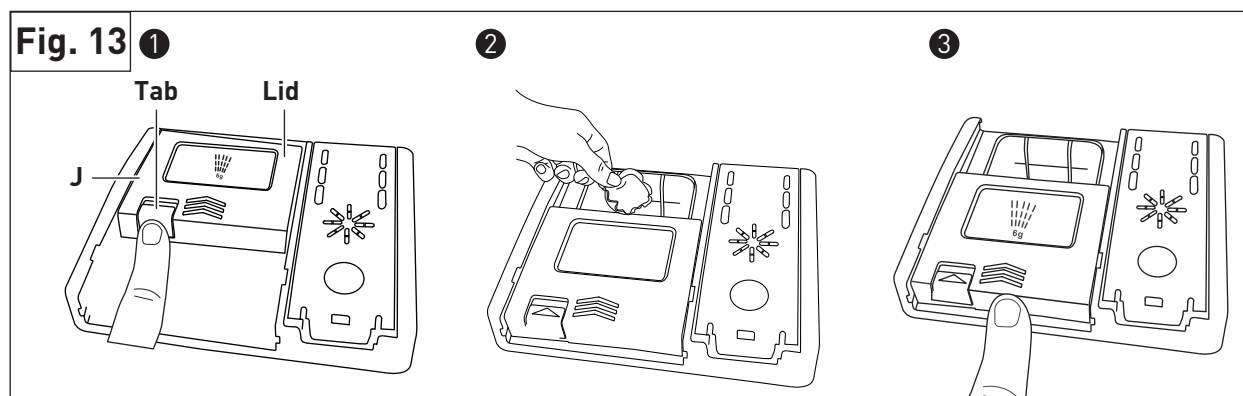

3.6 Adding rinse aid

Rinse aid prevents water from forming spots, streaks or droplets on the dishware and silverware. It is released during the final rinsing phase of the program.

- NOTICE**
- Only use rinse aid intended for dishwasher use.
 - The capacity of the rinse aid dispenser (J) is max. 1.7 oz (50 ml). Under normal use, this amount lasts around 1-3 months.
 - The ❄️ indicator (12) appears on the display (10) as a reminder to add rinse aid to the rinse aid dispenser (G).

1. Lift the tab of the rinse aid dispenser (G) lid to open it.
2. Add rinse aid to the dispenser until it reaches the **MAX** marking (Fig. 14).
3. Press the rinse aid dispenser (G) lid down firmly until it clicks into place (Fig. 14).

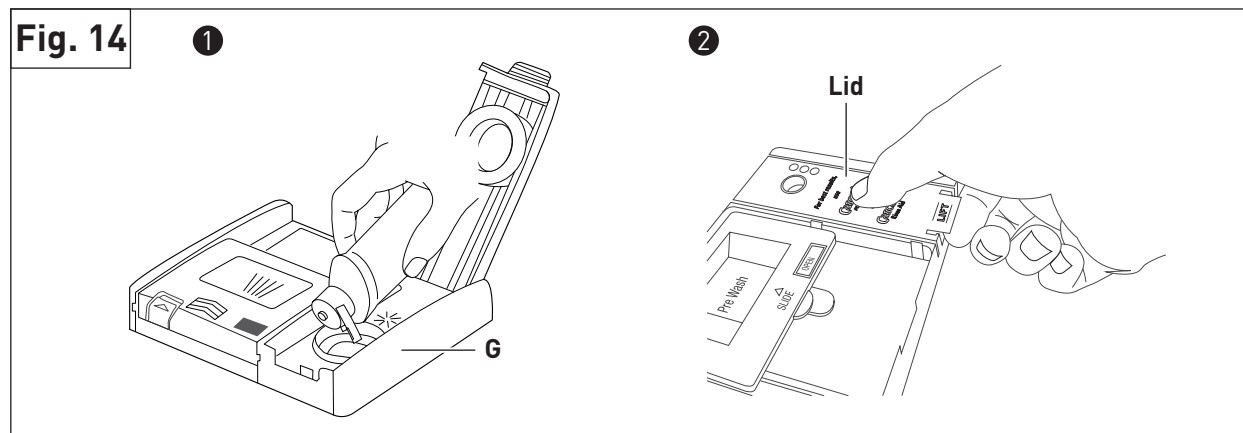

3.7 Unloading the appliance

Unload the racks (N, Q, W) and silverware basket (X) from the bottom to the top to prevent water dripping from dishware in the higher racks. Unload the lower rack (N), followed by the upper rack (Q), then the third rack (W).

4.1 Control panel description

- Use the control panel (H) to set the desired program, delay time and other settings (Fig. 15, Fig. 16).
- The appliance emits a beep tone when a button is pressed.
- Each button has an indicator that lights up when the button is pressed.
- If a program or setting is not able to be selected, the appliance emits 3 beep tones when the corresponding button is pressed.

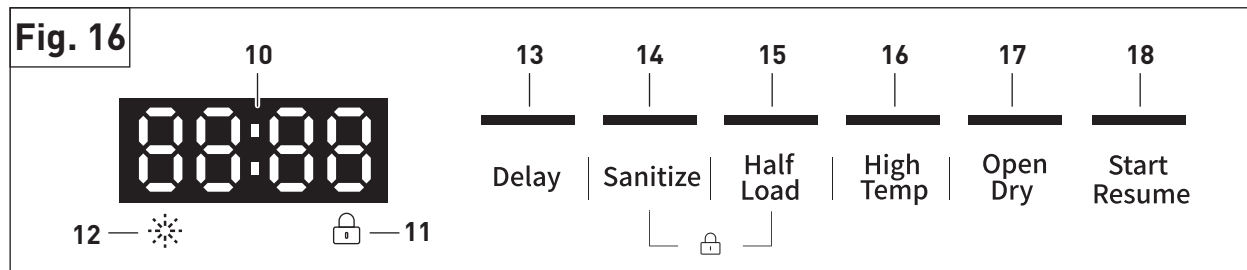
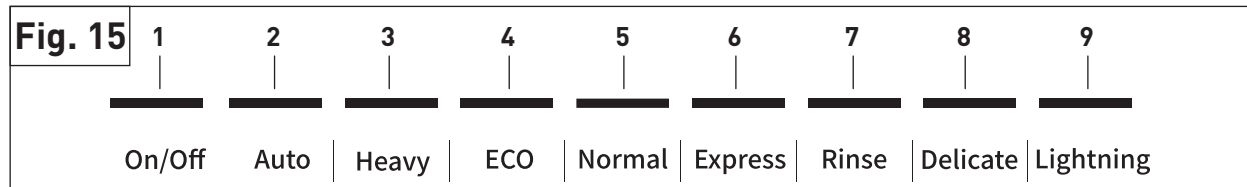

	Button/Indicator	Description
1	On/Off button	Switches the appliance on/off.
2	Auto button	Suitable for loads with stubborn grease and stuck-on food residue.
3	Heavy button	Automatically senses and adjusts the wash for mixed dishware and cookware with varying levels of food soil.
4	ECO button	Energy and water-saving mode for normally soiled items, including lightly soiled pots, pans, plates, and glasses.
5	Normal button	Regular daily cleaning of normally soiled loads.
6	Express button	Quick cleaning for lightly soiled loads without drying.
7	Rinse button	Rinses dishware, glasses and silverware for cleaning at a later time.
8	Delicate button	For lightly soiled fragile dishware and glassware.
9	Lightning button	For rinsing dishware and glassware.
10	Display	Shows delay time and error codes.
11	🔒 indicator	<ul style="list-style-type: none"> ● Activates child lock mode. Prevents buttons from being pressed during a cleaning cycle. ● Press and hold the Sanitize button (14) and Half Load button (15) at the same time for 3 seconds. The 🔒 indicator (11) appears on the display (10). If any button is pressed while the child lock mode is activated, the appliance emits 3 beep tones. ● The door can be opened and closed while the child lock mode is activated. ● To deactivate, press and hold the Sanitize button (14) and Half Load button (15) at the same time again for 3 seconds. The 🔒 indicator (11) disappears from the display (10).

OPERATION

	Button/Indicator	Description
12	☼ indicator	Indicates to add rinse aid to the rinse aid dispenser (G).
13	Delay button	<ul style="list-style-type: none"> ● Delays the start of the cleaning cycle. ● Press the Delay button (13) repeatedly to increase the delay time in increments of 30 minutes. Press and hold the Delay button (13) for 1 second to automatically increase the delay time in increments of 30 minutes. ● The maximum delay time is 24 hours.
14	Sanitize button	Increases the water temperature during washing to disinfect items.
15	Half Load button	Washes smaller loads with less energy and water.
16	High Temp button	Increases the water temperature during rinsing to help items dry faster.
17	Open Dry button	<ul style="list-style-type: none"> ● In the final stage of rinsing, the appliance automatically opens the door to release hot air, allowing for faster drying. Once the cleaning cycle is complete, the door opens to a set angle, while the door lock remains engaged. Open the door normally to unload the appliance. ● Avoid hitting or pushing the door after it opens automatically. This could damage the door mechanism.
18	Start/Resume button (18)	Starts a cleaning cycle.

4.2 Program overview

Program	Cycle Type	Cycle Time (Open Dry)	Cycle Time (No Open Dry)	Water Used (gal/L)	Pre-Wash Temp (°F/°C)	Main Wash Temp (°F/°C)	Rinse Temp (°F/°C)
Heavy	Standard	165 min	182 min	5.7 gal (21.6 L)	+122 °F (+50 °C)	+131 °F (+55 °C)	+158 °F (+70 °C)
	Sanitize	174 min	191 min	5.7 gal (21.6 L)	+122 °F (+50 °C)	+131 °F (+55 °C)	+158 °F (+70 °C)
	Half Load	164 min	181 min	4.75 gal (18 L)	+122 °F (+50 °C)	+131 °F (+55 °C)	+158 °F (+70 °C)
	High Temp	170 min	187 min	5.7 gal (21.6 L)	+122 °F (+50 °C)	+131 °F (+55 °C)	+158 °F (+70 °C)
ECO	Standard	148 min	165 min	3.01 gal (11.4 L)	Water inlet temp	+113 °F (+45 °C)	+140 °F (+60 °C)
	Sanitize	160 min	177 min	3.01 gal (11.4 L)	Water inlet temp	+113 °F (+45 °C)	+158 °F (+70 °C)
	High Temp	161 min	178 min	3.01 gal (11.4 L)	Water inlet temp	+140 °F (+60 °C)	+140 °F (+60 °C)
Delicate	Standard	117 min	134 min	3.70 gal (14 L)	Water inlet temp	+113 °F (+45 °C)	+140 °F (+60 °C)
	Sanitize	129 min	146 min	3.70 gal (14 L)	Water inlet temp	+113 °F (+45 °C)	+158 °F (+70 °C)

OPERATION

Program	Cycle Type	Cycle Time (Open Dry)	Cycle Time (No Open Dry)	Water Used (gal/L)	Pre-Wash Temp (°F/°C)	Main Wash Temp (°F/°C)	Rinse Temp (°F/°C)
	Half Load	116 min	133 min	3.17 gal (12 L)	Water inlet temp	+113 °F (+45 °C)	+140 °F (+60 °C)
	High Temp	130 min	147 min	3.70 gal (14 L)	Water inlet temp	+140 °F (+60 °C)	+140 °F (+60 °C)
Express	Standard	n/a	23 min	1.85 gal (7 L)	n/a	+113 °F (+45 °C)	n/a
Rinse	Standard	n/a	40 min	1.85 gal (7 L)	n/a	+113 °F (+45 °C)	+140 °F (+60 °C)
Lightning	Standard	n/a	14 min	0.92 gal (3.5 L)	n/a	+113 °F (+45 °C)	n/a
Normal (super H)*	Standard	144 min	161 min	5.34 gal (20.2 L)	Water inlet temp	+131 °F (+55 °C)	+140 °F (+60 °C)
	Sanitize	156 min	173 min	5.34 gal (20 L)	Water inlet temp	+131 °F (+55 °C)	+158 °F (+70 °C)
	Half Load	143 min	160 min	4.75 gal (20.2 L)	Water inlet temp	+131 °F (+55 °C)	+140 °F (+60 °C)
	High Temp	149 min	166 min	5.34 gal (20.2 L)	Water inlet temp	+140 °F (+60 °C)	+140 °F (+60 °C)
Normal (H)**	Standard	125 min	142 min	3.54 gal (13.4 L)	Water inlet temp	+131 °F (+55 °C)	+140 °F (+60 °C)
	Sanitize	137 min	154 min	3.54 gal (13.4 L)	Water inlet temp	+131 °F (+55 °C)	+158 °F (+70 °C)
	Half Load	124 min	141 min	3.17 gal (12 L)	Water inlet temp	+131 °F (+55 °C)	+140 °F (+60 °C)
	High Temp	130 min	147 min	3.54 gal (13.4 L)	Water inlet temp	+140 °F (+60 °C)	+140 °F (+60 °C)
Normal (M)***	Standard	112 min	129 min	3.54 gal (13.4 L)	Water inlet temp	+122 °F (+50 °C)	+140 °F (+60 °C)
	Sanitize	123 min	140 min	3.54 gal (13.4 L)	Water inlet temp	+122 °F (+50 °C)	+158 °F (+70 °C)
Normal (M)*** (con't)	Half Load	111 min	128 min	3.17 gal (12 L)	Water inlet temp	+122 °F (+50 °C)	+140 °F (+60 °C)
	High Temp	120 min	137 min	3.54 gal (13.4 L)	Water inlet temp	+140 °F (+60 °C)	+140 °F (+60 °C)
Normal (L)****	Standard	95 min	112 min	2.67 gal (10.1 L)	Water inlet temp	+113 °F (+45 °C)	+140 °F (+60 °C)
	Sanitize	106 min	113 min	2.67 gal (10.1 L)	Water inlet temp	+113 °F (+45 °C)	+158 °F (+70 °C)
	Half Load	94 min	111 min	2.38 gal (9 L)	Water inlet temp	+113 °F (+45 °C)	+140 °F (+60 °C)

OPERATION

Program	Cycle Type	Cycle Time (Open Dry)	Cycle Time (No Open Dry)	Water Used (gal/L)	Pre-Wash Temp (°F/°C)	Main Wash Temp (°F/°C)	Rinse Temp (°F/°C)
	High Temp	108 min	125 min	2.67 gal (10.1 L)	Water inlet temp	+140 °F (+60 °C)	+140 °F (+60 °C)
Auto (Super H)*	Standard	153 min	170 min	4.76 gal (18 L)	Water inlet temp	+131 °F (+55 °C)	+140 °F (+60 °C)
	Sanitize	164 min	181 min	4.76 gal (18 L)	Water inlet temp	+131 °F (+55 °C)	+158 °F (+70 °C)
	Half Load	152 min	169 min	4.23 gal (16 L)	Water inlet temp	+131 °F (+55 °C)	+140 °F (+60 °C)
	High Temp	158 min	175 min	4.76 gal (18 L)	Water inlet temp	+140 °F (+60 °C)	+140 °F (+60 °C)
Auto (H)**	Standard	134 min	151 min	3.75 gal (14.2 L)	Water inlet temp	+131 °F (+55 °C)	+140 °F (+60 °C)
	Sanitize	146 min	163 min	3.75 gal (14.2 L)	Water inlet temp	+131 °F (+55 °C)	+158 °F (+70 °C)
	Half Load	133 min	1+50 min	3.17 gal (12 L)	Water inlet temp	+131 °F (+55 °C)	+140 °F (+60 °C)
	High Temp	139 min	156 min	3.75 gal (14.2 L)	Water inlet temp	+140 °F (+60 °C)	+140 °F (+60 °C)
Auto (M)***	Standard	127 min	144 min	3.75 gal (14.2 L)	Water inlet temp	+122 °F (+50 °C)	+140 °F (+60 °C)
	Sanitize	138 min	155 min	3.75 gal (14.2 L)	Water inlet temp	+122 °F (+50 °C)	+158 °F (+70 °C)
	Half Load	125 min	142 min	3.17 gal (12 L)	Water inlet temp	+122 °F (+50 °C)	+140 °F (+60 °C)
	High Temp	135 min	152 min	3.75 gal (14.2 L)	Water inlet temp	+140 °F (+60 °C)	+140 °F (+60 °C)
Auto (L)****	Standard	104 min	121 min	2.88 gal (10.9 L)	Water inlet temp	+131 °F (+55 °C)	+140 °F (+60 °C)
	Sanitize	115 min	132 min	2.88 gal (10.9 L)	Water inlet temp	+113 °F (+45 °C)	+158 °F (+70 °C)
Auto (L)**** (con't)	Half Load	111 min	128 min	2.62 gal (9.9 L)	Water inlet temp	+113 °F (+45 °C)	+140 °F (+60 °C)
	High Temp	117 min	134 min	2.88 gal (10.9 L)	Water inlet temp	+140 °F (+60 °C)	+140 °F (+60 °C)

* Super H corresponds to super heavy soil level.

** H corresponds to heavy soil level.

*** M corresponds to medium soil level.

**** L corresponds to light soil level.

4.3 Starting or resuming a cleaning cycle

- NOTICE**
- To ensure an optimal temperature for washing, run hot water at the sink closest to the dishwasher until the water is hot, then turn the water off.
 - If the door is open longer than 4 seconds after starting a cleaning cycle (including if the Delay function is selected), it is necessary to press the **Start/Resume** button (18) again.
 - If the ☼ indicator (12) appears on the display (10), add rinse aid to the rinse aid dispenser (G).
1. Remove large pieces of food residue (e.g. bones, shells) from the dishware and silverware.
 2. Load the racks (N, Q, W) and silverware basket (X) from the back to the front and from the bottom to the top.
 3. Fill the detergent dispenser (J) and rinse aid dispenser (G) as needed.
 4. Press the **On/Off** button (1) to switch the appliance on. The **On/Off** button (1) indicator, **Auto** button (2) indicator and display (10) light up. The **Auto** program duration appears on the display (10).
 5. Press the corresponding button on the control panel (H) to select the desired program and settings.
 6. Lock the control panel (H) if necessary. To do so, press and hold the **Sanitize** button (14) and **Half Load** button (15) at the same time for 3 seconds. The  indicator (11) appears on the display (10).
 7. Press the **Start/Resume** button (18) to start the cleaning cycle.
 8. Firmly close the door within 4 seconds of pressing the **Start/Resume** button (18). If the door is not closed within 4 seconds, the **Start/Resume** button (18) flashes and the cleaning cycle does not start.
 9. As the cleaning cycle starts and progresses, the spotlight indicator (I) flashes then stays lit.
 10. When the cleaning cycle ends, the appliance emits a signal tone and the spotlight indicator (I) goes off. If no operation is made within 3 minutes, the appliance automatically switches off.
 11. After every cleaning cycle, leave the door slightly open for at least 30 minutes to release any moisture and odor.

4.4 Interrupting a cleaning cycle

⚠ CAUTION Risk of injury! The appliance may emit hot steam if it is opened mid-cycle. Keep the body away from the appliance and wear protective gloves if necessary.

NOTICE Pausing the cleaning cycle to add extra dishware is only possible before the detergent dispenser (J) opens.

1. Press the **Start/Resume** button (18) to pause the cleaning cycle. The button indicator and spotlight indicator (I) flash.
2. Open the door slightly to stop the cleaning cycle. Wait for the water to stop spraying, then open the door completely.
3. Check if the detergent dispenser (J) lid is open or closed. If it is open, the cleaning cycle has started and it is not recommended to add dishware or silverware.
4. If the detergent dispenser (J) cover is closed, add any extra dishware or silverware to the racks (N, Q, W) and silverware basket (X).
5. Close the door.
6. Press the **Start/Resume** button (18) again to resume the cleaning cycle. The button indicator and spotlight indicator (I) remain steady on.

OPERATION

4.5 Changing a program

NOTICE The program can only be changed at the early stages of a cleaning cycle. If the detergent has been released or if the wash water is drained, a new program has to be set and the detergent dispenser (J) must be refilled.

1. Press and hold the **On/Off** button (1) for 3 seconds to switch the appliance off. The button indicator goes off.
2. Press and hold the **On/Off** button (1) briefly to switch the appliance back on. The button indicator lights up.
3. Press the corresponding button on the control panel (H) to select the desired program and settings.
4. Press the **Start/Resume** button (18) to start the cleaning cycle. The button indicator and spotlight indicator (I) light up.

4.6 Canceling a cleaning cycle / Draining

1. Press and hold the **On/Off** button (1) for 3 seconds to switch the appliance off. The button indicator goes off.
2. Press and hold the **Start/Resume** button (18) for 5 seconds. The button indicator flashes and the appliance starts draining water.
3. The appliance switches off again 25 seconds after draining. The button indicator goes off.

CLEANING

5.1 General cleaning

- Unload any items from the racks (N, Q, W) and silverware basket (X) before cleaning.
- Do not let cooking grease or other flammable materials accumulate on the surfaces or near the appliance.
- Never use corrosive detergents, wire brushes, abrasive scourers, metal or sharp utensils to clean the appliance.
- Check that the appliance is switched off and all surfaces are cool before cleaning any part of the appliance.
- If the appliance is moved for servicing, check that the anti-tip restraints are re-engaged properly when the appliance is reinstalled.

Control panel

- Wipe the control panel (H) with a soft, damp microfiber cloth. Wipe dry with a dry cloth.
- Do not use spray cleaner on the control panel (H) to avoid penetration of water into the appliance.
- Do not use abrasive cleaners to prevent scratching.

Stainless steel surfaces

CAUTION Risk of damage! Do not use a steel-wool pad or abrasive cleaners to clean the surfaces. It may scratch the surfaces.

- It is recommended to use a stainless steel cleaner to remove fingerprints, dust and other residue.
- Clean the stainless steel surfaces when they are visibly dirty or dull.
- Follow the manufacturer's instructions indicated on the product packaging.

5.2 Cleaning the interior

CAUTION Health hazard!

Using detergents containing chlorine may result in harm to health.

- It is recommended to use dishwasher cleaning tablets once a month or as needed for effective removal of residue and stains on the interior surfaces. Build up of residue and stains may affect dishwasher performance over time.
1. Clean the filter assembly. Wash away any food residue and lock it back in place.
 2. Place one dishwasher cleaning tablet in the detergent tray without dishes and one tablet in the bottom of the dishwasher with dishes.
 3. Run a normal cycle.

5.3 Cleaning the filter assembly

CAUTION Risk of damage!

Never operate the appliance without the filter assembly (K). Using the appliance without the filter assembly (K) may damage the internal components.

- NOTICE**
- Check the condition of the filter assembly (K) and clean it at least once a month.
 - Do not overtighten the filter assembly (K). Make sure the filter assembly (K) is installed securely to prevent debris from entering the appliance.

1. Pull the lower rack (W) out from the appliance using the lower rack handle (Y).
2. Hold the top of the filter assembly (K) and rotate it counterclockwise to loosen it. Take the filter assembly (K) out of the appliance (Fig. 17).
3. Take off the inner filter from the top of the filter assembly (K) (Fig. 17).
4. Rinse the filters under running water. Use a soft cleaning brush to remove any remaining food residue or debris.
5. Reassemble the filters in the reverse order of disassembly. Place the filter assembly (K) into the appliance and rotate it clockwise to tighten it.

CLEANING

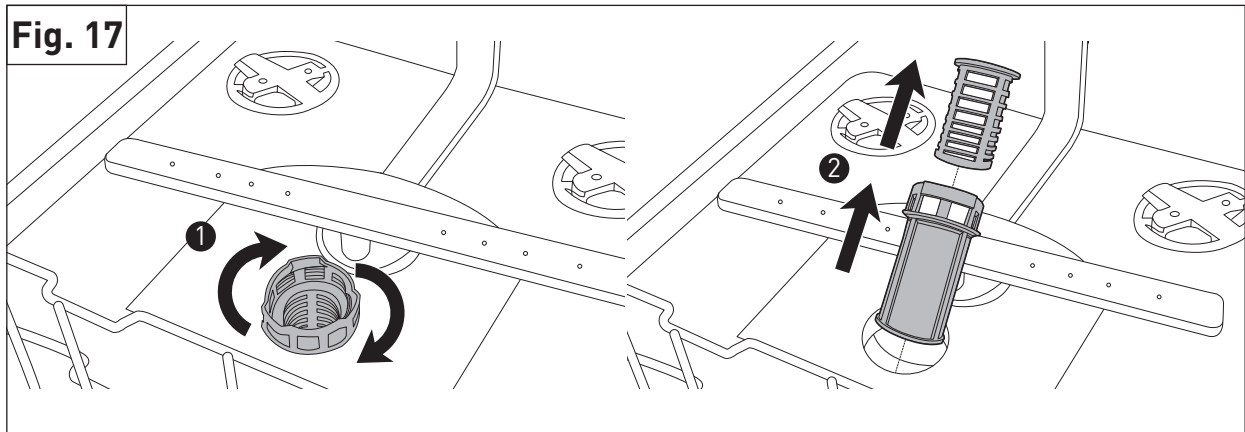

5.4 Cleaning the spray arms

NOTICE Check the condition of the spray arms (F, T) and clean them at least once a month.

1. To remove the upper spray arm (T), hold the nut in the center and rotate the upper spray arm counterclockwise (Fig. 18).
2. To remove the lower spray arm (F), pull it upwards (Fig. 18).
3. Wash the spray arms (F, T) in warm, soapy water. Use a soft cleaning brush to remove any residue from the jets.
4. Rinse the spray arms (F, T) thoroughly under running water.
5. Reinstall the spray arms (F, T).

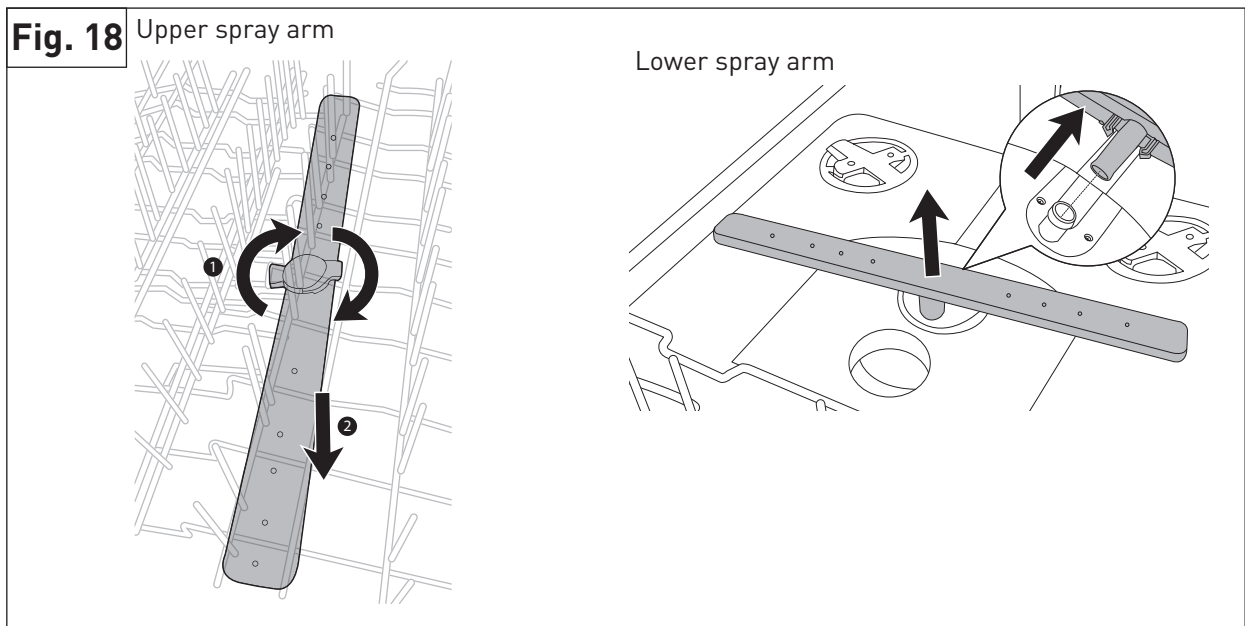

MAINTENANCE

6.1 Maintenance guidelines

- Unload any items from the racks (N, Q, W) and silverware basket (X) before performing maintenance or servicing.
- Switch off the power to the appliance at the main fuse or circuit breaker. If in doubt, contact an electrician.
- If the appliance is moved for servicing, check that the anti-tip restraints are re-engaged properly when the appliance is reinstalled.
- Always disconnect the appliance from the electrical supply before servicing.
- Any other servicing than mentioned in this manual should be performed by a professional repair center.

6.2 Preparing for extended absence

If the appliance is not going to be used for a long time, run the Auto program without a load. Once complete, switch off the power to the appliance, close the water supply and leave the door slightly open. This helps the door seals to last longer and prevent odors from forming inside the appliance.

6.3 Preparing for winter

Perform these steps after a cleaning cycle in winter to prevent frost from forming inside the appliance: These steps should only be applied in colder areas to prevent frost from forming inside the appliance after a cleaning cycle during winter. In warmer regions, these precautions may not be needed.



1. Disconnect the appliance from the power source.
2. Switch off the water supply and disconnect the water inlet pipe from the water valve.
3. Run the Half Load program to drain any remaining water from the water inlet pipe and water valve.
4. Reconnect the water inlet pipe to the water valve.
5. Remove the filter assembly (K) at the bottom of the inner cavity. Soak up any water with a sponge or absorbent cloth.

6.4 Purchase replacement parts

For purchasing replacement parts, ensure compatibility by referencing the appliance model number and serial number, then contact Thor by:

Contact	Phone number	Email
Thor's parts department	877-288-8099 (option 5)	parts@thorinternational.com
Customer service	877-288-8099 (option 3)	service@thorinternational.com

TROUBLESHOOTING

Problem	Possible cause	Solution
The appliance does not switch on.	The electrical wiring is not connected to the power supply.	Check if the wire connections inside the junction box are secure. Use a voltage tester at the junction box to verify if the wires are powered.
	The fuse is blown, or the circuit breaker has tripped.	Replace fuse or reset circuit breaker. Remove any other appliances sharing the same circuit with the appliance.
	Water pressure is low.	Check that the water supply is connected properly and the water is switched on.
	The door is not closed.	Open the door then firmly close it.
		Make sure that dishware is not preventing the door from closing. Adjust the position of the items as necessary.
Child lock mode is activated. The  indicator (11) appears on the display (10).	Deactivate child lock mode. Press and hold the Sanitize button (14) and Half Load button (15) at the same time for 3 seconds. The  indicator (11) disappears from the display (10).	
Water remains in the interior of the appliance or does not drain.	The drain hose is twisted or kinked.	Reposition the drain hose so water can flow freely through it.
	The filter assembly (K) is clogged.	Clean the filter assembly (K). See chapter 5.3 Cleaning the filter assembly .
	The kitchen sink is clogged.	Check that the kitchen sink can drain properly. If the kitchen sink is not draining, consult a plumber.
	The appliance detected suds.	Unload all items from the appliance. To remove the suds, pour 1.06 gal (4 L) of water into the interior base of the appliance. Close the door, then select any program to flush away the suds. Open the door after the cleaning cycle is complete to check if the suds are gone. Repeat the steps if any suds remain.
The appliance is leaking.	The appliance is not level.	Level the appliance. Refer to the Installation manual .
	The appliance was not installed properly.	Contact customer service.

TROUBLESHOOTING

Problem	Possible cause	Solution
The appliance is not drying the dishware.	The rinse aid dispenser (G) is empty.	Add rinse aid to the rinse aid dispenser (G) before starting a cleaning cycle.
	The open dry setting was not selected.	Select the open dry setting before starting a cleaning cycle.
	The dishware is not correctly loaded.	Load dishware using the recommended loading pattern. See chapter 3.4 Suggested loading patterns .
	The dishware was unloaded too early.	Wait at least 15 minutes after a cleaning cycle has completed to let the dishware dry off and cool down.
	The wrong program was selected.	Select a program that allows the open dry setting to be used. See chapter 4.2 Program overview .
There are suds in the appliance.	Wrong type of detergent is used.	Only use detergent intended for dishwashers. To remove the suds, pour 1.06 gal (4 L) of water into the interior base of the appliance. Close the door, then select any program to flush away the suds. Open the door after the cleaning cycle is complete to check if the suds are gone. Repeat the steps if any suds remain.
	Too much detergent was used.	Use less detergent.
	The rinse aid dispenser (G) lid was not closed properly.	Press the rinse aid dispenser (G) lid down firmly until it clicks into place.
Water does not drain properly.	The cleaning cycle was interrupted.	Firmly close the door then press the Start/Resume button (18) to resume the cleaning cycle.
	The filter assembly (K) is clogged.	Clean the filter assembly (K). See chapter 5.3 Cleaning the filter assembly .
There is white residue on the interior of the appliance.	Mineral buildup from water.	Clean the interior of the appliance. See chapter 5.2 Cleaning the interior .
		Install a water softener if the area has hard water. Contact a plumber if necessary.
The appliance emits bad odors.	The filter assembly (K) is clogged.	Clean the filter assembly (K). See chapter 5.3 Cleaning the filter assembly .
	The appliance is not used frequently and the door is kept closed.	Clean the interior of the appliance. See chapter 5.2 Cleaning the interior .
Abnormal noises are coming from the appliance.	A spray arm (F, T) is hitting an item in the racks (N, Q, W) or silverware basket (X).	Pause the program and rearrange the dishware to make sure no items are blocking the spray arms (F, T).
	Dishes are moving inside the appliance.	Pause the program and rearrange the dishware to secure all items in place.

TROUBLESHOOTING

Problem	Possible cause	Solution
Dishware is not clean.	The dishware is not correctly loaded.	Load dishware using the recommended loading pattern. See chapter 3.4 Suggested loading patterns .
	The program is not powerful enough for the amount of food soil.	Wash the dishware again on a more intensive program. See chapter 4.2 Program overview .
	There is not enough detergent.	Add more detergent or use a different detergent with stronger cleaning capabilities.
	The spray arms (F, T) are blocked or not rotating freely.	Pause the program and rearrange any dishware blocking the spray arms (F, T) so that they can rotate freely.
	The filter assembly (K) is clogged.	Clean the filter assembly (K). See chapter 5.3 Cleaning the filter assembly .
Dishware is damaged.	The dishware is not correctly loaded.	Load dishware using the recommended loading pattern. See chapter 3.4 Suggested loading patterns .
Button indicators are flashing.	Button indicators flash when a cleaning cycle is paused or when a cleaning cycle has been interrupted by opening the door.	If the Start/Resume button (18) indicator is flashing, press the Start/Resume button (18) and close the door within 4 seconds.
		If the spotlight indicator (I) or other button indicators are flashing and the appliance is not working as expected, contact customer service.
Glassware is cloudy.	Not enough rinse aid was added to the rinse aid dispenser (G).	Add rinse aid to the rinse aid dispenser (G) until it reaches the MAX marking.
	Too much or not enough detergent was used.	Add an appropriate amount of detergent to the detergent dispenser (J).
There is white residue on the dishware.	Mineral buildup from water.	Install a water softener if the area has hard water. Contact a plumber if necessary.
		Make sure to add rinse aid to the rinse aid dispenser (G). See chapter 3.6 Adding rinse aid .
The interior of the appliance is stained.	Water contains high iron content.	Clean the interior of the appliance. See chapter 5.2 Cleaning the interior .
	Dishware is covered with large amounts of tomato-based or acidic residue.	Remove as much food residue from the dishware as possible before loading the appliance.
Detergent does not release during a cleaning cycle.	Dishes are blocking the detergent dispenser (J) from opening.	Rearrange the dishes so that they are not blocking the detergent dispenser (J).

ERROR CODES

⚠ WARNING

- If overflow occurs, switch the main water supply off before consulting a professional repair service.
- If water has leaked into the base due to an overflow or small leak, remove the water before restarting the appliance.

Error code	Possible cause
E1	Not enough water flowing through the inlet.
E2	The inlet valve is faulty.
E4	Appliance overfills and leaks.
E5	The communication between internal parts during a cleaning cycle is faulty.
E6	NTC (Negative Temperature Coefficient) is faulty.
E11	Auto-open door function is faulty.
E14	The communication between the display board and the main control board is faulty.

WARRANTY

THOR
K I T C H E N[®]

Warranty & Service

This appliance has been manufactured by Thor International, 4651 E Airport Drive, California 91761

For Customer Service, please call (877) 288 - 8099

For the most up to date warranty and service policy, please refer to our website

WWW.THORKITCHEN.COM/WARRANTY-REGISTRATION

For in-warranty service requests, please visit our website at

WWW.THORKITCHEN.COM/SERVICE

Please Note: For any inquiries regarding service or products, please provide the serial number of the item in order to process requests efficiently.



WELCOME TO THE GORDON RAMSAY COLLECTION

THOR Kitchen x Gordon Ramsay Collection is backed by a solid two-year warranty on both parts and labor. It's our commitment to quality and your peace of mind. Registering your appliance ensures top-notch service and personalized support. Your registration helps us stay informed about your appliance, enabling us to provide timely maintenance reminders, updates, and exclusive offers. This ensures your appliance maintains peak performance for years to come.

01 Scan the QR Code or visit thorkitchen.com/register-your-product.

02 Input your purchase and product information and select register.

03 That's it. You're all set. Start cookin'!

