

**Version** FDVRG36W5SS-R / Built-in 36" (90 cm) - 500 CFM  
**Collection** Design

**FEATURES AND PROPERTIES**

**Materials/Finishes** Scotch brite stainless steel  
**Technology** SRS Speed reduction system  
**Features** Slide out glass panel  
 Automatic shut-off timer  
 Clean filter reminder  
**Control** Electronic control  
**Ducting type** Extracting/Filtering  
**Chimney** Possible to duct wall mounted from rear  
**Installation type** Insert  
**Lighting** LED 2x1,2 W - 2700 K / 5600 K  
**Filters** Metallic grease filter, removable and washable  
 Charcoal filter (optional)  
**Ducting type**  
**Dimensions** 36 in  
**Notes** Availability Carbon.Zeo filter KACL.1039 for hoods produced from Sept. 2024



Photograph is for information purposes only. May not correspond to the selected version

**ELECTRICAL CONNECTION AND CONSUMPTION**

**Maximum consumption** 280 W  
**Voltage/Frequency** 110-120V 60Hz

**BLOWER PERFORMANCE**

**Motor** 500 CFM  
**Minimum sound level** 0 dB (A)re1pW I.E.C. 60704-2-13  
**Maximum sound level** 0 dB (A)re1pW I.E.C. 60704-2-13

**WEIGHTS AND DIMENSIONS**

**Gross weight** 34 lbs  
**Net weight** 26 lbs  
**Volume** 7 ft  
**Packaging dimensions** L 40 x H 17 x D19 in

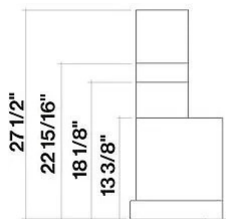
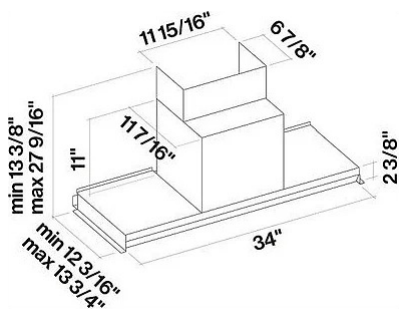

**OPTIONAL ACCESSORIES**

<i>Code</i>	<i>Description</i>
KACL.107	Glass shelf 90 cm
KCVJN.01#3	Kit Chimney Virgola-Move H120 Stainless Steel
KCVJN.00#3	KIT CHIMNEY VIRGOLA-MOVE H=185 + Ext. H=185 Stainless Steel
KACL.960	Charcoal filter
KACL.1039	Carbon.Zeo Microtech renewable filter