

Kenmore^{®/MD}



Convertible Upright Freezer/Fridge 14 cu. ft.



Customer Assistance
1-800-265-8456
www.koolatron.com

KKUF14-W
Use & Care Guide

CONTENTS

SAFETY WARNINGS	03
PRODUCT OVERVIEW	05
PRODUCT INSTALLATION	06
OPERATION INSTRUCTIONS	10
CLEANING AND MAINTENANCE	14
TROUBLESHOOTING	16

SAFETY WARNINGS



Warning: risk of fire / flammable materials

- This appliance is intended to be used in household and similar applications such as staff kitchen areas in shops, offices and other working environments; farm houses and by clients in hotels, motels and other residential type environments; bed and breakfast type environments; catering and similar non-retail applications.
- This appliance is not intended for use by persons (including children) with reduced physical, sensory or mental capabilities, or lack of experience and knowledge, unless they have been given supervision or instruction concerning use of the appliance by a person responsible for their safety.
- Children should be supervised to ensure that they do not play with the appliance.
- If the supply cord is damaged, it must be replaced by the manufacturer, its service agent or similarly qualified persons in order to avoid a hazard.
- Do not store explosive substances such as aerosol cans with a flammable propellant in this appliance.
- The appliance has to be unplugged after use and before carrying out user maintenance on the appliance.
- **WARNING:** Keep ventilation openings, in the appliance enclosure or in the built-in structure, clear of obstruction.
- **WARNING:** Do not use mechanical devices or other means to accelerate the defrosting process, other than those recommended by the manufacturer.
- **WARNING:** Do not damage the refrigerant circuit.
- **WARNING:** Do not use electrical appliances inside the food storage compartments of the appliance, unless they are of the type recommended by the manufacturer.
- **WARNING:** Please abandon the refrigerator according to local regulators for it use flammable blowing gas and refrigerant.
- **WARNING:** When positioning the appliance, ensure the supply cord is not trapped or damaged.
- **WARNING:** Do not locate multiple portable socket-outlets or portable power supplies at the rear of the appliance.
- Do not use extension cords or ungrounded (two prong) adapters.

- **WARNING:** Risk of child entrapment. Before you throw away your old refrigerator or freezer:
 - Take off the doors.
 - Leave the shelves in place so that children may not easily climb inside.
- The refrigerator must be disconnected from the source of electrical supply before attempting the installation of accessory.
- Refrigerant and cyclopentane foaming material used for the appliance are flammable. Therefore, when the appliance is scrapped, it shall be kept away from any fire source and be recovered by a special recovering company with corresponding qualification other than be disposed by combustion, so as to prevent damage to the environment or any other harm.
- To prevent a child from being entrapped, keep out of reach of children and not in the vicinity of freezer (or refrigerator). (Suitable for products with locks)
- **WARNING:** To avoid a hazard due to instability of the appliance, it must be fixed in accordance with the instructions.

PRODUCT OVERVIEW

Names of components

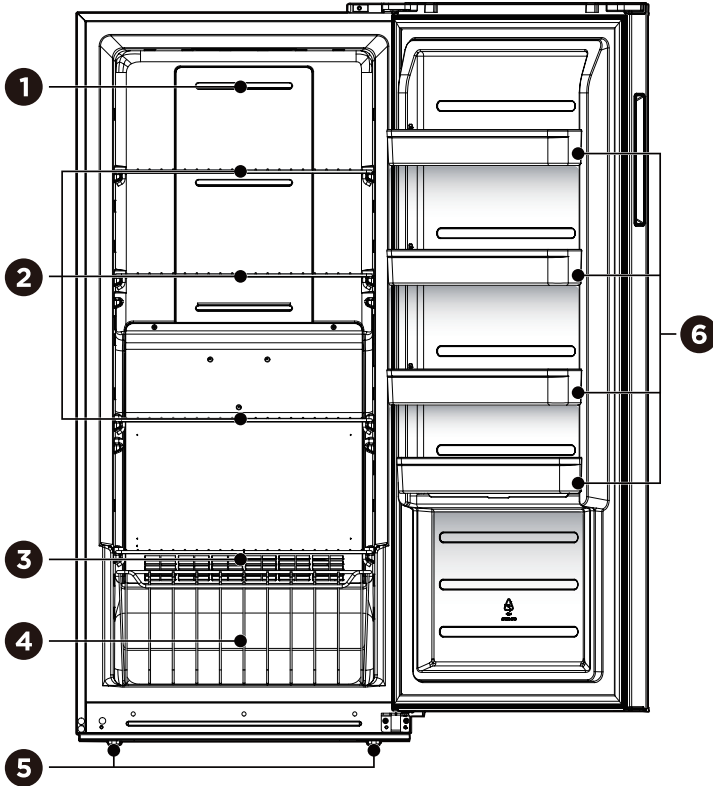

1 Air flow outlet

2 Shelf

3 Air flow inlet

4 Drawer

5 Leveling feet

6 Door bin

ATTENTION

The picture above is only for reference. The actual configuration will depend on the physical product or statement by the distributor.

PRODUCT INSTALLATION

Install Instruction

Finding a suitable location

- This refrigerator is designed to be free standing only, and should not be recessed or built-in.
- The refrigerator should be placed in a well-ventilated indoor place; the ground shall be flat and sturdy.
- Keep away from heat and avoid direct sunlight. Do not place the refrigerator in moist or watery places to prevent rust or reduction of insulating effect.

Dimensions and Clearances

- Too small of a distance from adjacent items may result in the degradation of freezing capability and increased electricity costs. Allow over 100 mm of clearance from each adjacent wall when installing the appliance.

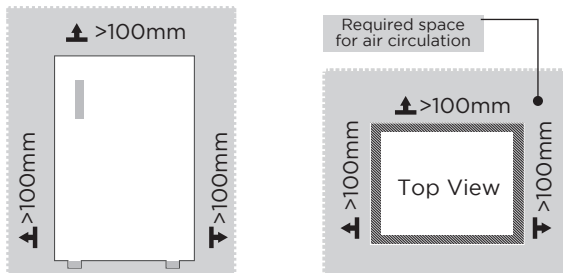

Providing a proper power supply

- Check your local power source. This refrigerator requires a 115 V, 60 Hz power supply.
- Use a receptacle that accepts the grounding prong. The power cord is equipped with a 3-prong (grounding) plug which mates with a standard 3-prong (grounding) wall outlet to minimize the possibility of electric shock hazard from this refrigerator.



CAUTION

The freezer should always be plugged into its own individual electrical outlet which has a voltage rating that matches the rating plate.

Never unplug your freezer by pulling on the power cord. Always grip the plug firmly and pull straight out from the outlet.

Start to use

- The freezer shall stay for half an hour before connecting power when it is firstly started.
- The freezer shall run 2 to 3 hours before loading fresh or frozen foods; the freezer shall run for more than 4 hours in summer in advance considering that the ambient temperature is high.

Space requirement diagram (when the door is open and when the door is closed)

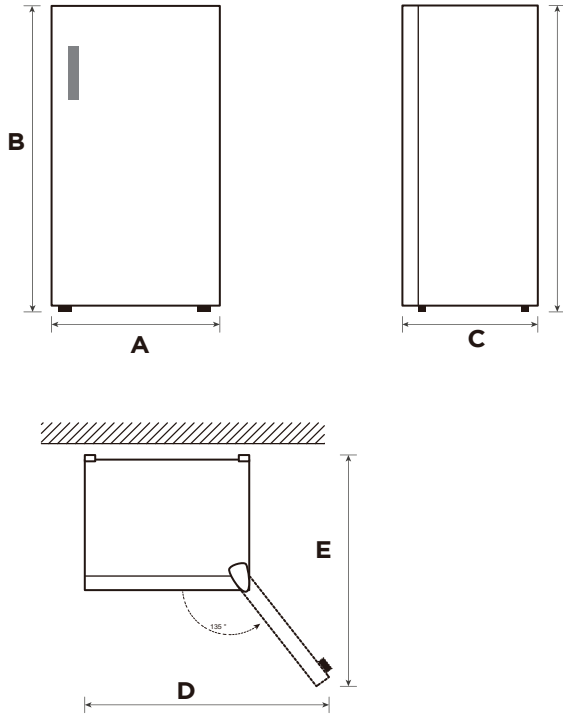

Width	Overall Height	Depth	Width doors open 135°	Depth doors open 135°
A	B	C	D	E
711	1570	750	1230	1242

Notice: All dimensions in mm



Leveling feet

To avoid vibration, the unit must be leveled.

If required, adjust the leveling screws to compensate for the uneven floor.

The front should be slightly higher than the rear to aid in door closing.

Leveling screws can be turned easily by tipping the cabinet slightly.

Turn the leveling screws counterclockwise  to raise the unit, clockwise  to lower it.

Moving the appliance

1. Remove all food from inside the appliance.
2. Pull the power plug out, insert and fix it into the power plug hook at the rear or on top of the appliance.
3. Tape parts such as shelves and the door handle to prevent from falling off while moving the appliance.
4. Move the appliance with more than two people carefully. When transporting the appliance over a long distance, keep the appliance upright.
5. After installing the appliance, connect the power plug into a socket out to switch on the appliance.

Changing the light

- Any replacement or maintenance of the LED lamps is intended to be made by the manufacturer, its service agent or similar qualified person.

Connecting the appliance

After installing the appliance, connect the power plug into a socket outlet.

ATTENTION

- After connecting the power supply cord (or plug) to the outlet, wait 2 or 3 hours before you put food into the appliance. If you add food before the appliance has cooled completely, your food may spoil.

Precautions before operation:

- Before making changes the refrigerator must be disconnected from power.
- Precautions should be taken to prevent any personal injury.

Tips for energy saving

- Do not place the appliance near cookers, radiators or other heat sources. If the ambient temperature is high, the compressor will run more frequently and for longer, resulting in increased energy consumption.
- Ensure that there is sufficient ventilation at the base of the appliance, on the sides of the appliance and at the back of the appliance. Never cover ventilation openings.
- Please also observe the spacing dimensions in the chapter "Installation".
- The arrangement of drawers, shelves and racks as shown in the illustration offers the most efficient use of energy and should therefore be retained as far as possible. All drawers and shelves should remain in the appliance to keep the temperature stable and save energy.
- To obtain a larger storage space (e.g. for large refrigerated/frozen goods), the middle drawers can be removed. The top and bottom drawers and shelves should be removed last if necessary.
- An evenly filled refrigerator/freezer compartment contributes to optimal energy use. Therefore, avoid empty or half-empty compartments.
- Allow warm food to cool before placing it in the refrigerator/freezer. Food that has already cooled down increases energy efficiency.
- Allow frozen food to defrost in the refrigerator. The coldness of the frozen food reduces the energy consumption in the refrigerator compartment and thus increases the energy efficiency.
- Open the door only as briefly as necessary to minimise cold loss. Opening the door briefly and closing it properly reduces energy consumption.
- The door seals of your appliance must be perfectly intact so that the doors close properly and energy consumption is not increased unnecessarily.

OPERATION INSTRUCTIONS

Control panel

IMPORTANT: The control panel automatically locks after 30 seconds of inactivity to prevent accidental activation. Unlock the control panel for use.

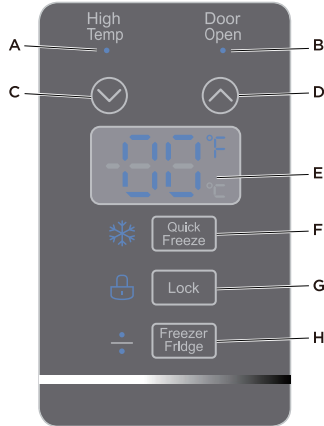

A	High temperature indicator / alert
B	Door open indicator / alert
C	Decrease temperature button
D	Increase temperature button
E	Temperature display
F	Quick freeze button
G	Control panel lock / unlock button
H	Freezer / Fridge mode button

Set Temperature

This freezer can be used as either a freezer or refrigerator (fridge) for your food storage needs; however the default temperature setting is 0 °F (-18 °C).

- Freezer mode temperature range: 10 °F ~ -11 °F (-12 °C ~ -24 °C).
- Fridge mode temperature range: 35 °F ~ 46 °F (2 °C ~ 8 °C).

NOTES:

If the freezer is unplugged or loses power, you must wait 3 to 5 minutes before restarting it. The freezer will not start if you attempt to restart it sooner.

If you choose to adjust the temperature setting, allow several hours for the temperature to stabilize between adjustments.

Lock



To manually lock or unlock the control panel for use: Press and hold  for 3 seconds.

NOTE: Depending on the state of the Control Panel (locked or unlocked), the Lock icon will either illuminate (locked) or turn off and a beep will sound.

Refrigerator/Freezer Mode



This freezer has an advanced design feature that lets you change it from a freezer to a refrigerator. You can switch from Freezer mode to Refrigerator mode only by using the control panel.

The Freezer / Fridge light on the control panel indicates the current mode.

1. Press and hold  for 3 seconds to unlock the control panel.
2. Press and hold  for 3 seconds to change modes. The panel beeps and the indicator light changes to the mode selected.

Quick Freeze

The Quick Freeze feature lowers the temperature below the normal operating temperature to quickly freeze foods.



1. Press and hold  for 3 seconds to unlock the control panel.
2. Press  to select Quick Freeze mode. The blue snowflake icon illuminates.

NOTE: You can press  a second time to exit quick freeze mode.



The Quick Freeze mode turns off automatically:

- After 3 hours, if the temperature falls below -13 °F (-25 °C).
- After 24 hours, if the temperature does not fall below -13 °F (-25 °C).

Temp Display (°F VS °C)

1. Press and hold  for 3 seconds to unlock the control panel.
2. Press and hold  or  for 3 seconds to switch between Fahrenheit and Celsius.

Return to Factory Default Settings

1. Press and hold  for 3 seconds to unlock the control panel.
2. Press  and  buttons at the same time for 3 seconds to reset the freezer controls to the factory default settings.

NOTE: The control panel will beep and all indicators will illuminate for 3 seconds. If the compressor is running, it will pause for 5 minutes, and then restart.

Additional Features

High Temperature Alert

If the freezer is having trouble maintaining a cold temperature, the LED on the control panel will illuminate and a beep will sound.

- FREEZER MODE: The interior temperature is over 18 °F (-8 °C) for 36 hours.
- FRIDGE MODE: If the interior temperature is over 59 °F (15 °C) for 36 hours.
- If the temperature returns to within normal range, the alert turns off automatically.
- Press any button on the control panel to turn off the alert.

Possible Causes:

- The room is too warm e. g. the freezer is in a garage in the summer next to a car with a hot engine.
- The freezer ventilation openings are blocked or dusty.
- There are door seal gaps.

Door Open Alert

If the door is open for longer than 5 minutes, the Door Open alert is activated; the LED on the control panel will illuminate and a buzzer will sound intermittently.

To turn off the Door Open alert, close the freezer door.

- Make sure that no items are blocking the door open to prevent it from closing completely.
- Make sure the freezer is level. The door may not close properly if the freezer is not level. See, “Leveling.”

Temp Out of Range Alert (e.g. Power Failure)

If there is a difference of at least 12.6 °F (7 °C) between the set temperature and the interior temperature 42 hours after you shut the door, an alert will sound.

- If the temperature returns to within normal range, the alert will turn off automatically.
- Press any button on the control panel to turn off the alert.

Possible causes for the temperature to be out of range:

- Power failure.
- The room is too warm or cold.
- The freezer ventilation openings are blocked or dusty.
- There are door seal gaps.

Error Codes

Code	Meanings	Cause	Solution
E2	Temperature sensor fault	Temperature sensor failure.	Call for service.
E5	Defrost sensor fault	Defrost sensor failure.	Call for service.
E7	Ambient temperature sensor fault	Ambient temperature sensor failure.	Call for service.
High Temp and Door Open alerts			See “Additional Features.”

Tips on storing food

Freezer compartment

- The freezer is designated for the storage of food frozen at very low temperature, long-term storage of frozen food, and for the production of ice.
- Only use the shelves in the door of the freezer to store frozen food, not for storing hot food designated for freezing.
- Do not put fresh and frozen food next to each other. The frozen food may thaw.
- When freezing fresh food (such as meat, fish or chopped meat), cut them into parts that can be used at the same time.
- Storing frozen food: instructions are usually stated on the packages, which must be followed. If there is no information on the packaging, food should not be stored for longer than three months from the date of purchase.
- When purchasing frozen food, make sure that it was frozen at a suitable temperature and that the packaging is not damaged.
- Frozen food should be kept in suitable packages to retain the quality and should be returned to the freezer compartment as soon as possible.
- If a package of frozen food shows moisture or abnormal bulging, it is probable that it was stored at the wrong temperature and the content is spoiled.
- The storage period for frozen food depends on the room temperature, the thermostat setting, the frequency of opening the door of the freezer, the type of food and the time of transporting the product from the shop to the household. Always follow the instructions printed on the packaging and never exceed the maximum storage time stated on the package.

Cooling compartment

- To reduce moisture and subsequent ice build-up, never put liquid into the refrigerator in unsealed containers. Frost tends to concentrate in the coolest parts of the evaporator. Storing uncovered liquids results in a more frequent need for defrosting.
- Never put warm foods in the refrigerator. These should first cool down at room temperature and then be placed so as to ensure adequate air circulation in the refrigerator.
- Foods or food containers should not touch the back wall of the refrigerator because they could freeze to the wall. Do not keep regularly opening the door of the refrigerator.
- Meat and clean fish (packed in a package or plastic foil) can be placed in the refrigerator, which can be used in 1-2 days.
- Fruit and vegetables without packaging can be placed in the part designated for fresh fruit and vegetables.

ATTENTION

The optimal temperature setting of each compartment depends on the ambient temperature. Above optimal temperature is based on the ambient temperature of 25 °C.

CLEANING AND MAINTENANCE

Defrost

- The refrigerator is made based on the air-cooling principle and thus has automatic defrosting function. Frost formed due to change of season or temperature may also be manually removed by disconnection of the appliance from power supply or by wiping with a dry towel.

Stop using

Power failure:

In case of power failure, even if it is in summer, foods inside the appliance can be kept for several hours; during the power failure, the times of door opening shall be reduced, and no more fresh food shall be put into the appliance.

Long-time nonuse:

The appliance shall be unplugged and then cleaned; then the doors are left open to prevent odor.

Moving:

Before the refrigerator is moved, take all objects inside out, fix the glass partitions, vegetable holder, freezing chamber drawers and etc. with tape, and tighten the leveling feet; close the doors and seal them with tape. During moving, the appliance shall not be laid upside down or horizontally, or be vibrated; the inclination during movement shall be no more than 45°.

ATTENTION

The appliance shall run continuously once it is started. Generally, the operation of the appliance shall not be interrupted; otherwise the service life may be impaired. Foods can be preserved for a couple of hours even in summer in case of power failure; it is recommended to reduce the frequency of opening door.

Cleaning of door tray

- According to the direction arrow in the figure below, use both hands to squeeze the tray, and push it upward, then you can take it out.
- After washing the tray having been taken out, you can adjust its installing height in accordance with your requirement.

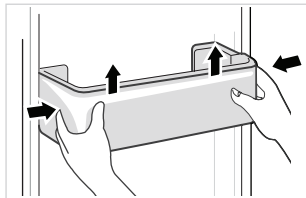

Cleaning of glass shelf

- As the innermost part of the refrigerator liner where contacting the shelves has a backstop, you shall raise the shelves upward, then you can be able to take it out.
- Adjust or clean the shelves according to your requirement.

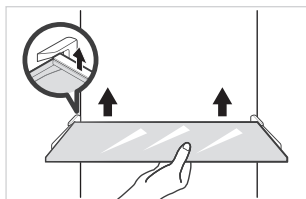

Cleaning the vegetable drawer

1. Remove the contents of the drawer. Hold the handle of the vegetable drawer and pull it out completely until it stops.
2. Lift the vegetable drawer up and remove it by pulling it out.

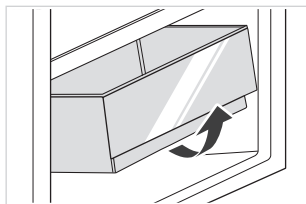

● ATTENTION

Soft towels or sponge dipped in water and non-corrosive neutral detergents are suggested for cleaning. The freezer shall be finally cleaned with clean water and dry cloth. Open the door for natural drying before the power is turned on. Do not use hard brushes, clean steel balls, wire brushes, abrasives, such as toothpastes, organic solvents (such as alcohol, acetone, banana oil, etc.), boiling water, acid or alkaline items clean refrigerator considering that this may damage the fridge surface and interior.

TROUBLESHOOTING

The following simple issues can be handled by the user. Please call the after-sale service department if the issues are not solved.

Problem	Possible reason
Failed operation	<ul style="list-style-type: none"> • Check whether the appliance is connected to power or whether the plug is in well contact
	<ul style="list-style-type: none"> • Check whether the voltage is too low
	<ul style="list-style-type: none"> • Check whether there is a power failure or partial circuits have tripped
Odor	<ul style="list-style-type: none"> • Odorous foods shall be tightly wrapped
	<ul style="list-style-type: none"> • Check whether there is any rotten food
	<ul style="list-style-type: none"> • Clean the inside of the refrigerator
Long-time operation of the compressor	<ul style="list-style-type: none"> • Long operation of the refrigerator is normal in summer
	<ul style="list-style-type: none"> • When the ambient temperature is high it is not suggestible having too much food in the appliance at the same time
	<ul style="list-style-type: none"> • Food shall get cool before being put into the appliance
	<ul style="list-style-type: none"> • The doors are opened too frequently
Light fails to get lit	<ul style="list-style-type: none"> • Check whether the refrigerator is connected to power supply and whether the illuminating light is damaged
	<ul style="list-style-type: none"> • Have the light replaced by a specialist
Door can not be properly closed	<ul style="list-style-type: none"> • The door is stuck by food packages too much food is placed
	<ul style="list-style-type: none"> • The refrigerator is tilted.
Loud noises	<ul style="list-style-type: none"> • Check whether the floor is level and whether the refrigerator is placed stably
	<ul style="list-style-type: none"> • Check whether accessories are placed at proper locations

Problem	Possible reason
Door seal fails to be tight	<ul style="list-style-type: none"> • Remove foreign matters on the door seal
	<ul style="list-style-type: none"> • Heat the door seal and then cool it for restoration (or blow it with an electrical drier or use a hot towel for heating)
Water pan overflows	<ul style="list-style-type: none"> • There is too much food in the chamber or food stored contains too much water, resulting in heavy defrosting
	<ul style="list-style-type: none"> • The doors are not closed properly, resulting in frosting due to entry of air and increased water due to defrosting
Hot housing	<ul style="list-style-type: none"> • Heat dissipation of the built-in condenser via the housing, which is normal when housing becomes hot due to high ambient temperature, storage of too much food or shutdown of the compressor is shut down, provide sound ventilation to facilitate heat dissipation
Surface condensation	<ul style="list-style-type: none"> • Condensation on the exterior surface and door seals of the refrigerator is normal when the ambient humidity is too high. Just wipe the condensate with a clean towel.
Abnormal noise	<ul style="list-style-type: none"> • Buzz: The compressor may produce buzzes during operation, and the buzzes are loud particularly upon start or stop. This is normal.
	<ul style="list-style-type: none"> • Creak: Refrigerant flowing inside of the appliance may produce creak, which is normal.

WARRANTY

2 Year Limited Warranty

FOR TWO YEARS from the date of sale this product is warranted against defects in material or workmanship.

WITH PROOF OF SALE a defective product will be repaired or replaced free of charge.

The Kenmore brand is used under license. Direct all claims for warranty service to Koolatron Customer Assistance, call 1-800-265-8456 or email service@koolatron.com

This warranty covers manufacturer's defects including electrical and mechanical defects provided the appliance is correctly assembled, operated and maintained according to the supplied instructions. It does not cover damage caused by accident, misuse or abuse including overheating, unauthorized repairs or alterations, or use with a voltage converter or aftermarket accessories, and it does not apply to scratches, stains, discoloration or other surface damage that does not impair the product function. This warranty is void if the appliance is ever used for purposes other than private household use.

Koolatron Corporation
4320 Federal Drive, Batavia, NY 14021 U.S.A.
139 Copernicus Blvd., Brantford, ON N3P1N4 Canada

Kenmore and the Kenmore logo are registered trademarks
to Transform SR Brands Management LLC
and are used under license by Koolatron Corporation

H1S396
9/2023-v1