



# CHARCOAL GRILLS

## Owner's Manual

PRO22K-CART-3, PRO22K-LEG-3 & PRO18K-LEG-3,  
NK22K-LEG-3 & NK18K-LEG-3  
COSPRO22K-LEG-3-C

Grills illustrated in this manual may differ from model purchased.

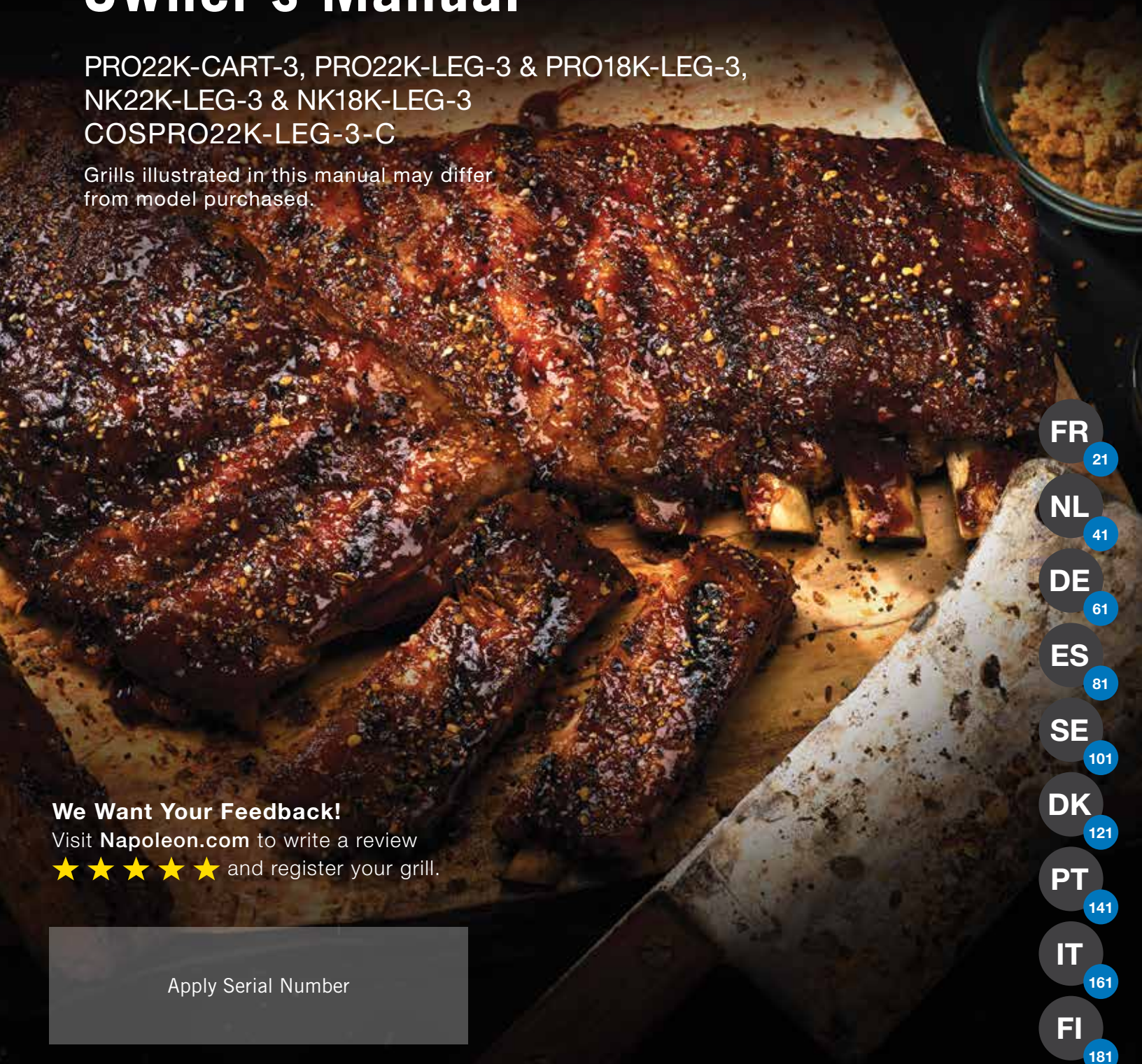

### We Want Your Feedback!

Visit [Napoleon.com](http://Napoleon.com) to write a review  
★★★★★ and register your grill.

Apply Serial Number

FR 21

NL 41

DE 61

ES 81

SE 101

DK 121

PT 141

IT 161

FI 181

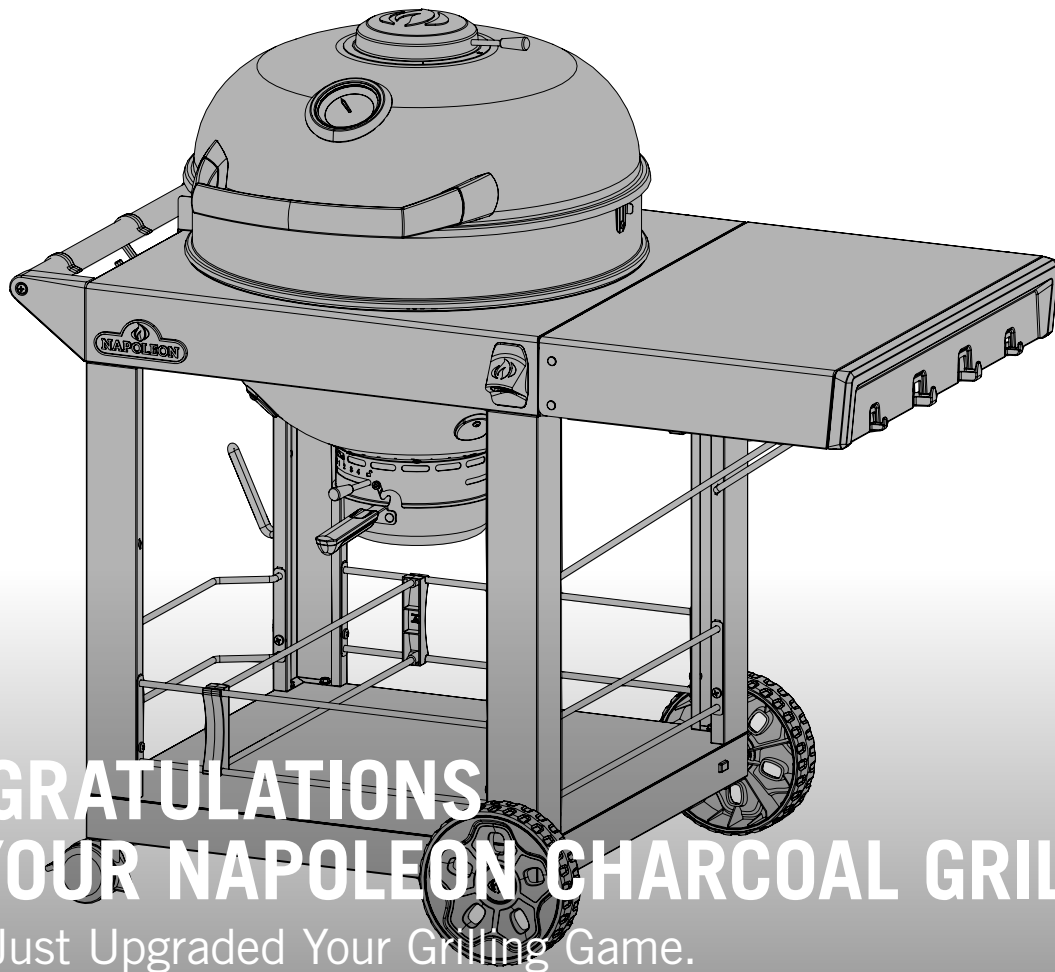

# CONGRATULATIONS ON YOUR NAPOLEON CHARCOAL GRILL!

You've Just Upgraded Your Grilling Game.

**WE WANT YOUR GRILLING EXPERIENCE TO BE MEMORABLE AND SAFE.**

Please read and follow this Owner's Manual before using your grill to avoid property damage, personal injury, or death.

Remove all packaging material, promotional labels and cards from the grill before use.

**USE OUTDOORS IN A WELL-VENTILATED SPACE.**

**DO NOT OPERATE IN A BUILDING, GARAGE, OR ANY OTHER ENCLOSED AREA.**

## **DANGER!**

- Burning charcoal gives off carbon monoxide.
- Do not burn charcoal or use the barbecue in a confined and/or habitable space such as houses, garages, tents, vehicles, caravans, motor homes, or boats. Danger of carbon monoxide poisoning fatality.
- Extinguish any open flame.



## **WARNING!**

Do not try to light this appliance without reading the "LIGHTING" instructions section of this manual.

Do not store or use gasoline, or other flammable liquids or vapors in the vicinity of this or any other appliance.

If the information in these instructions is not followed exactly, a fire or explosion may result and cause property damage, personal injury, or death.



Alert adults and children about the hazard of hot surface temperatures. Supervise young children near the grill.

**NOTICE TO INSTALLER:** Leave these instructions with the grill owner for future reference.

**NOTICE TO CONSUMER:** Keep these instructions for future reference.

# Welcome to Napoleon!

## SAFETY FIRST



### WARNING General Information

Do not use spirit, alcohol, gasoline, petrol, or other highly volatile fluids to light or re-light charcoal. Use ONLY firelighters complying with EN 1860-3. Make sure any fluids that have drained through the bottom of the grill are removed before lighting the charcoal.



### WARNING! Installation & Assembly

Assemble this grill exactly as instructed in the Assembly Guide. If the grill was assembled in-store, review the assembly instructions to ensure it is assembled correctly.

This grill must not be installed in or on recreational vehicles and/or boats.

Do not modify this grill under any circumstances.



### WARNING! Operation

Read this entire Owner's Manual before operating this charcoal grill.

DO NOT operate unit under any combustible construction.

Follow the lighting instructions carefully.

Do not use indoors.

Keep children and pets away.

This barbecue will become very hot. Do not move it during operation.



### WARNING! Storage & Disuse

Store outdoors in a well-ventilated space away from children and pets.

After use, charcoal starter fluid should be capped and stored a safe distance away from the grill at least 25ft (7.6m).



## CONTENTS

Welcome to Napoleon!	3
Safety First	
Full System Features	4
Getting Started	6
Additional Safe Operating Practices	
Charcoal Starter Safe Operating Practices	
Operation	7
Lighting your grill	
Grilling Instructions	
How to use the Rotisserie	
The Grilling Experience Checklist	
How to season cast iron cooking grids	
Charcoal Grilling Guide	13
Cleaning Instructions	14
Maintenance Instructions	15
Troubleshooting	17
Warranty	18



1-866-820-8686  
+31 345 588655



grills@napoleon.com  
eu.service@napoleon.com



www.napoleon.com

# Full System Features

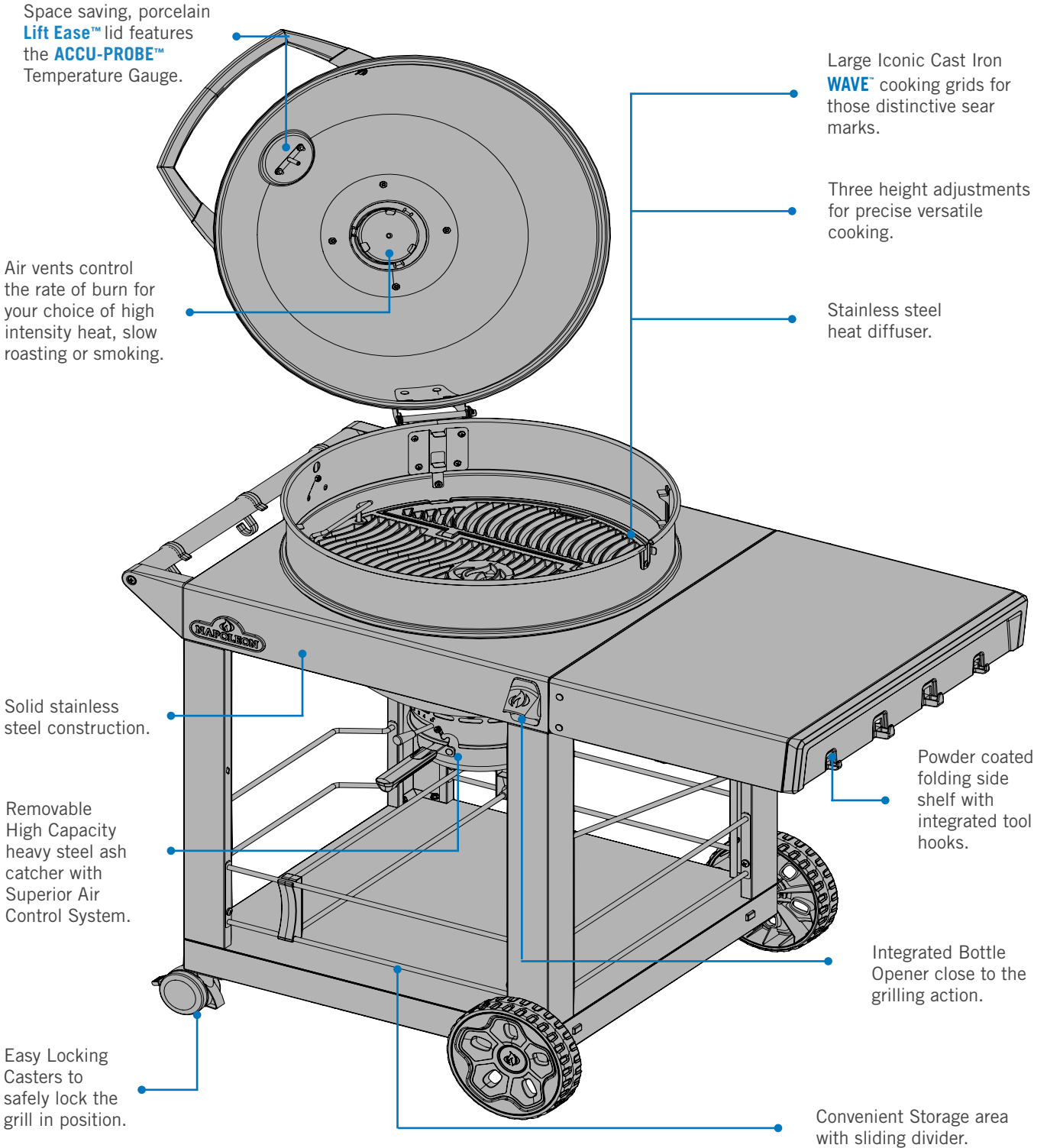

The grills illustrated in this Owner's Manual may differ from the model you purchased. Featured model: PRO22K-CART-3

Space saving, porcelain **Lift Ease™** lid features the **ACCU-PROBE™** Temperature Gauge.

Ergonomic hinged lid for safe operation over the entire cooking surface.

Cast Iron hinged cooking grids with three height adjustments.

Stainless steel heat diffuser.

Adjustable cast aluminum hinge.

Rotisserie ready stainless ring with multi-position cooking grid heights.

Sturdy Handle, doubles as a tool holder.

Heavy Gauge black porcelain lid and bowl.

Removable High Capacity heavy steel ash catcher with Superior Air Control System.

Convenient heavy gauge storage shelf.

Sturdy Four Stainless steel legs with large wheels to navigate any terrain. 7" for 18" models 8" for 22" models

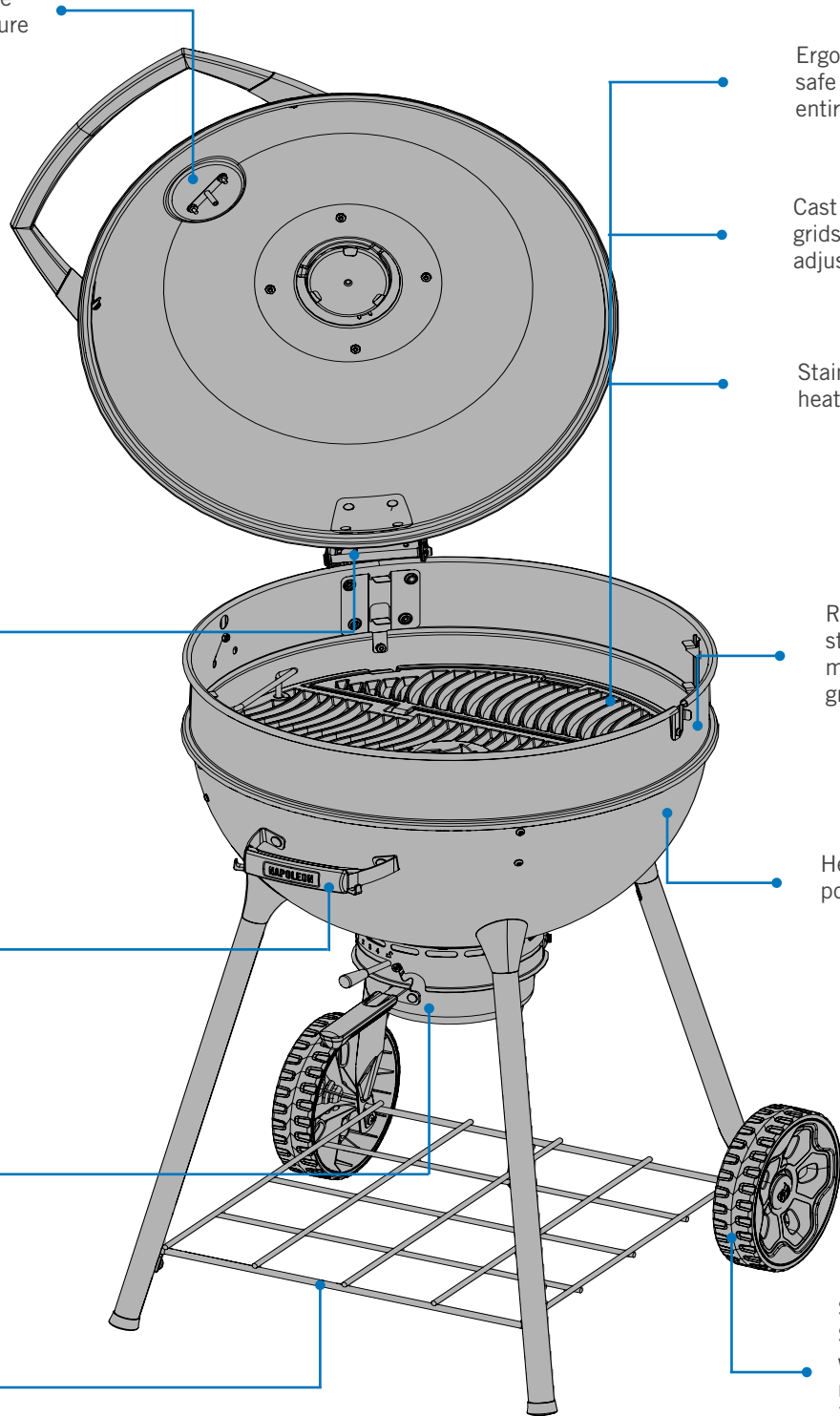

The grills illustrated in this Owner's Manual may differ from the model you purchased. Featured model: PRO22K-3

# Getting Started



**DANGER / WARNING!** Advises of a hazard that could result in a fire, explosion, death or serious physical injury.



**WARNING / CAUTION!** Advises of a hazard that could result in minor physical injury or property damage.



Wear protective gloves.



Wear safety glasses.



**CAUTION!** Hot surface.



Important information

## ADDITIONAL SAFE OPERATING PRACTICES

- This grill must be stored outdoors in a well-ventilated area and must not be used inside building, garage, screened in porch, gazebo, or any enclosed area.
- DO NOT operate this grill under any overhead construction such as roof coverings carports, awnings, or overhangs.
- The grill should be on a secure, level ground at all times.
- DO NOT light charcoal with lid closed.
- DO NOT lean over grill when lighting.
- Keep lid closed during the preheat period.
- DO NOT leave grill unattended while in use.
- Keep children and pets away from hot grill.
- DO NOT allow children to climb inside or on grill.
- Maintenance should only be done when the grill is cool.
- Always allow the grill to cool completely before handling.
- DO NOT use side shelves to store lighters, matches or any other combustibles.
- Keep all electrical cords away from water or heated surfaces.
- Keep ventilated openings of the enclosure free and clear from debris at all times.
- The ash/grease tray must be in place when using the grill.
- Clean the ash/grease tray regularly to avoid build-up that may lead to grease fires.
- Remove coal and ashes from grill and store in a noncombustible metal container filled with water. Allow to remain in metal container 24 hours before disposing.
- To prevent mold growth, leave the top and bottom air vents slightly open when storing for extended periods of time.
- DO NOT use water to control flare ups or extinguish coals. It may damage your grills finish.
- Slightly close the vents on your grill to control flare-ups. Close all vents and lid completely to extinguish coals/fire.
- Always maintain a minimum distance to combustible materials of 3' (0.914m) to rear and sides of grill.

## CHARCOAL STARTER SAFE OPERATING PRACTICES

- For outdoor use only.
- Do not use the Charcoal Starter unless it is placed on a firm, level charcoal grate, and the charcoal grill is on a firm, level, non-combustible surface.
- Do not place the Charcoal Starter on any combustible surface unless the Charcoal Starter is completely cool.
- Do not use lighter fluid, gasoline, or self lighting charcoal in the Charcoal Starter.
- We recommend the Charcoal Starter to light charcoal for charcoal grills.
- Always wear protective gloves when handling the Charcoal Starter.
- Keep children and pets away from the Charcoal Starter at all times.
- Do not use the Charcoal Starter in high winds.
- Do not leave the Charcoal Starter unattended while in use.
- Never use the Charcoal Starter other than intended use.
- Do not use the Charcoal Starter to prepare food.
- Use extreme caution when pouring hot coals out of the Charcoal Starter.

**CAUTION!** Charcoal starter fluid should never be added to hot or warm coals.

**CAUTION!** Do not remove ashes from grill until all charcoal is completely burned out and fully extinguished. Allow ample time to cool.

**CAUTION!** Do not move the grill when operating and hot.



# Operation

## LIGHTING YOUR GRILL

### Is it the very first time? Perform a Burn-off

Add fuel to the grill and keep it red hot for 30 minutes with the lid and base vents fully open. It is normal for the grill to emit an odor the first time it is lit. This odor is caused by the “burn-off” of internal paints and lubricants used in the manufacturing process and will not occur again.

Use either the Charcoal Starter (not included) and follow the instructions included in the manual, OR place lighter cubes or lightly crumpled newspaper on and around the air deflector.

Place the charcoal in a cone shaped pile in the center of the unit (direct cooking method), or the optional charcoal baskets (indirect method). **NOTE:** Do not cook before the charcoal has a coating of ash.

### How to use the Charcoal Starter

1. See “**Charcoal Starter Safe Operating Practices**” for best practices on how to use the Charcoal Starter in a safe manner.
2. Turn the Charcoal Starter upside down.
3. Crumple two full sheets of newspaper and stuff them into the bottom of the Charcoal Starter.
4. Turn the Charcoal Starter right side up and place it in the center of the charcoal grate.
5. Add appropriate amount of charcoal, but do not over fill.
6. Light a match and insert into one of the bottom air vents to ignite the newspaper.
7. Put on protective gloves (minimum thermal protection Class II, DIN EN 407). When the top layer of charcoal has a light coating of gray ash, carefully pour the hot charcoal onto the charcoal grate (direct cooking method), or place into the charcoal baskets (indirect method).
8. Once the hot charcoal is placed into the grill, spread the charcoal out evenly using tongs with long heat resistant handles.



**WARNING!** Do not lean over grill when lighting charcoal.

**WARNING!** Starter fluid can be used to light the charcoal, but it is not the preferred method. It can be messy and may leave a chemical taste on the food if not completely burned off prior to cooking.



### Operating Bottom Vent and Ash Bucket

Lid vents on a covered grill are usually left open to allow air into the grill. Air increases the burning temperature of the coals.

You can regulate the coals burn rate by moving the vent handle to the right (Open) or left (Closed).

Closing the vents either partially or completely will help to cool down the coals.

Do not completely close the air vents and the lid vent unless you are trying to cool down or extinguish a flame.

The Ash bucket can be removed as needed during and after operation to dispose any charcoal deposits. See “Disposing of Charcoal and Ash” in the “Cleaning Instructions”.

OPEN

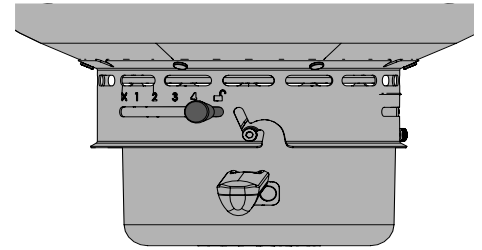

CLOSED

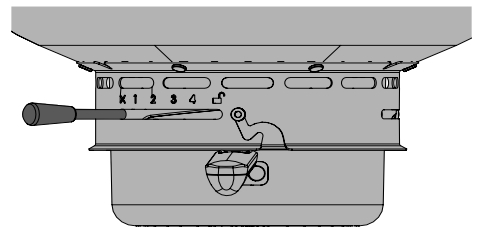

#### GRILLING PRO TIP!



Use barbecue mitts, or hot pads to protect hands while cooking or adjusting the vents.

### Operating the Chimney vents

The Chimney vent is used to control the internal temperature of the grill. This is usually left open in order for smoke to escape and fine tune the temperature of the grill when the lid is closed.

You can regulate the grill's temperature by moving the vent handle to the right (Closed) or left (Open).

OPEN

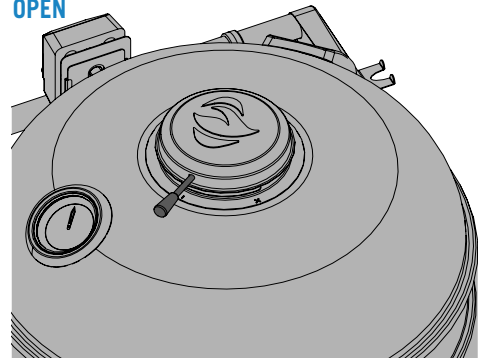

CLOSED

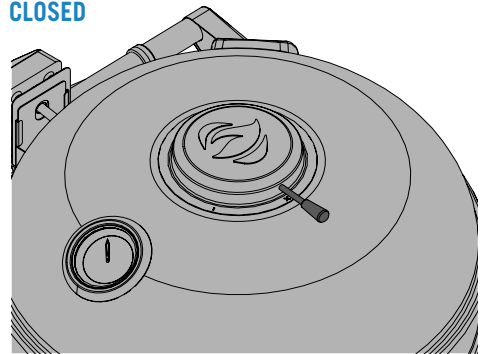

#### GRILLING PRO TIP!



It's best to control temperature by using the different settings on the bottom vent. The top vent should be positioned either fully open or fully closed.

#### GRILLING PRO TIP!



Apply vegetable oil for smooth vent operation.

**WARNING!** Always wear protective gloves when using the Charcoal Starter for your grill.

**WARNING!** Do not locate in windy settings. High winds adversely affect the cooking performance of the grill.





## GRILLING INSTRUCTIONS

### Grilling with Charcoal

Charcoal is the traditional way of cooking that produces fabulous flavors. The glowing briquettes emit infrared energy to the food being cooked, which has very little drying effect. Any juices or oils that escape from the food drip down onto the charcoal and vaporize into smoke giving the food its delicious grilled taste. Napoleon's charcoal grill produces searing heat for juicier, tastier steaks, hamburgers, and other meats. For cooking times and tips refer to the **"Charcoal Grilling Guide" on page 13.**

As a general rule, plan on using about 50 briquettes to cook 2 lb. (1kg) of meat, or 100 briquettes to cook 4 lb. (2kg) of meat. If cooking for more than 30 to 40 minutes, additional briquettes must be added to the fire. When the weather is cold you will need more briquettes to reach ideal cooking temperatures. Longer cooking times will require additional charcoal.

Use caution when adding charcoal to the grill. Flames may flare up when coals come in contact with fresh air. Stand back a safe distance and use a long-handled heat-resistant cooking tongs to add charcoal briquettes.

Additional smoke flavor can be achieved by adding smoker chips, which are available in a variety of flavors through your Napoleon dealer.

### Charcoal Usage

Charcoal recommendations are approximate. Longer cooking times require additional charcoal.

Model	Cooking Method	Lump Charcoal Weight Recommendation	Br. Charcoal Recommendation (Maximum Pieces)	Additional Charcoal +1hour
PRO18K / NK18K	Direct Grilling	0.80 kg	40	8 per side
PRO22K / NK22K	Direct Grilling	0.98 kg	50	8 per side
	Indirect Grilling	0.49 kg	25 per side	8 per side

#### SAFETY FIRST



Never cover more than 75% of cooking surface with any solid metal (e.g. griddles or pans).

#### DID YOU KNOW?



There are flaps on either side of the cooking grid that provide access to the glowing charcoal (if applicable).

**WARNING!** Ash pan must be in place during lighting and anytime during use.

**WARNING!** Once lit, never add additional starter fluid to the grill. Store the bottle at least 25 ft. (7.6m) away from the grill when operating. Once charcoal is ignited, no more fluid is required.

**WARNING!** Use caution when adding charcoal to the grill. Flames may flare up when coals come in contact with fresh air. Stand back a safe distance and use long-handled, heat-resistant cooking tongs to add additional charcoal.



## Using the Grill

- We recommend preheating the grill with the lid closed for approximately 20 minutes.
- The coals are ready when they have a light coating of gray ash.
- Food cooked for short periods of time such as fish and vegetables can be grilled with the lid open.
- Cooking with the lid closed ensures higher and more even temperatures that will reduce cooking time, and cook the food more uniformly.  
**NOTE:** To minimize heat loss when checking food temperature, use the temperature probe doors located at the side of the appliance.
- When cooking very lean meat such as chicken breast or lean pork, the grids can be oiled before preheating to reduce sticking.
- Cooking meat with a high degree of fat content may create flare-ups. Either trim the fat, or reduce temperatures to inhibit this.
- Should a flare-up occur, move food away from flames and reduce the heat (reduce vent opening). Leave the lid open until flare-up is controlled.

### GRILLING PRO TIP!



Use a thermometer to check the internal temperature of meat to ensure it is cooked perfectly.

## Direct Grilling

This method is often used for searing, or food cooked for only a short time such as hamburgers, steaks, chicken, or vegetables.

Place food on the cooking grids directly over the heat.

Sear meat first to trap-in the juices and flavor.

Lower the grill temperature to finish cooking to your preference or placing the food in the indirect cooking zone of the grill to finish cooking

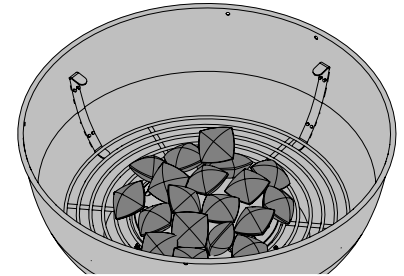

## Indirect Grilling

This method uses lower temperatures and circulates heat around the food cooking it slowly and evenly. Use this method to cook larger cuts of meat, or food prone to flare-ups such as roast, chicken, or turkey.

Place food on the cooking grid where there is no direct heat from underneath.

Grilling at a lower temperature and cooking for a longer duration without direct heat from underneath will result in more tender meats.

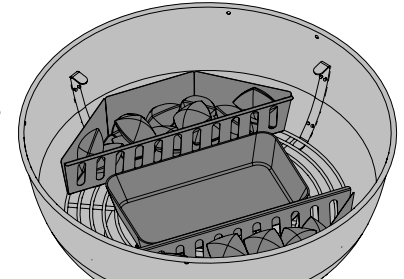

## Adjusting Grid Height

**Note:** PRO22K and PRO18K only.

The height of the cooking grid can be adjusted to 3 different levels to accommodate cooking needs. This can be adjusted by lifting and turning the cooking grid clockwise or counter clockwise while using the handles.

The lowest level is best for searing (it's closest to the coals).

The middle for standard cooking.

The Highest level is best for slow cooking or keeping food warm by leaving the lid open.

**CAUTION!** Do not adjust the cooking grid while in operation or hot.

**WARNING!** Never place your hands inside the grill when adjusting the charcoal tray. Keep hands and fingers away from lifting mechanism at all times.

**WARNING!** Use caution when adding charcoal to the grill. Flames may flare up when coals come in contact with fresh air.

**WARNING!** Stand back a safe distance and use long-handled, heat-resistant cooking tongs to add additional charcoal.

**WARNING!** Never leave coals and ashes unattended in grill.





## THE GRILLING EXPERIENCE CHECKLIST

Refer to this list every time you grill

**Read Owner's Manual**

Be sure to have read the owner's manual and all the safety instructions.

**Clean ash pan**

Always ensure you clean the ash pan prior to grilling to avoid fires and flare-ups.

**Lighting charcoal**

Fully open the vent on the lid and base each time you light your grill. Use the Charcoal Starter (not included), or place lighter cubes or lightly crumpled newspaper on and around the air deflector. Do not lean over grill when lighting charcoal.

**Preheat and clean grids**

Coat entire surface of grids with vegetable shortening NOT salted fats like butter or margarine. Preheat your grill to burn off excess residue. Clean grids with a brass wire brush. Refer to "Cleaning Instructions".

**NOTE:** Stainless steel cooking grids are durable and corrosion resistant and require less seasoning and maintenance than cast iron grids.

**Prep area**

Make sure everything you need while grilling such as your utensils, seasonings, sauces, and dishes are within your reach. Don't leave your food unattended, or it could burn.

**Don't peek and flip once**

Try not to open the lid and peek too much, or heat will escape and throw your temperature and cooking times off. Flip your food only once, especially steak and chicken.

**Leave space**

Leave some space on the grill and between food, so you have room to move food around if you need to.

**Use a thermometer**

Use a thermometer to ensure food is cooked thoroughly. Follow the appropriate temperatures guidelines for all types of meat, especially poultry.

### GRILLING PRO TIP!



Get inspired to create delicious meals from the recipes and grilling techniques at [www.napoleon.com](http://www.napoleon.com) and Napoleon's cookbooks.

### GRILLING PRO TIP!



Always preheat the grill before cooking to burn off leftover residue and prevent food from sticking to the grate.

### OIL AND FAT SUGGESTION!



- Grapeseed Oil
- Sun Flower Oil
- Soybean Oil
- Extra Virgin Olive Oil
- Canola Oil

If not available, select an oil or fat that has a high smoke point. Do not use salted fats like butter or margarine.

## HOW TO SEASON CAST IRON COOKING GRIDS







This procedure **MUST** be done prior to first use and repeated every 3-4 uses to keep grids looking new.

1. Remove cast iron grids from the grill.
2. Wash grids with warm soapy water and soft cloth. Pat dry and allow grids to completely dry.
3. Apply fat/oil evenly using a silicone brush on both sides.
4. Preheat appliance to 350°F - 400°F (176°C - 204°C).
5. Install cooking grids and cook for 30 minutes.
6. Apply a second even coat of fat/oil on cooking grids, and keep cooking for 30 more minutes.
7. Grids are now seasoned.

**NOTE:** If rust has formed on the cast iron grids, remove the rust with scouring pad or brass brush and repeat the seasoning process.



# Charcoal Grilling Guide

FOOD	GRILLING METHOD	COOKING TIME	SUGGESTIONS
 <b>Steak</b> 1 inch (2.54 cm) thick	Direct Heat	Rare – 4 minutes	Ask for marbled fat in cut. Fat is a natural tenderizer and keeps meat juicy.
		Medium – 6 minutes	
		Well done – 8 minutes	
 <b>Hamburger</b> ½ inch (1.27 cm) thick	Direct Heat	Rare – 4 minutes	Keep patties all the same thickness for equal cooking times. Add hickory-flavored wood chips to the charcoal for extra flavor.
		Medium – 6 minutes	
		Well done – 8 minutes	
 <b>Chicken</b>	Direct Heat - approx. 2 minutes per side	20 – 25 minutes	Slice joint connecting the thigh and leg ¾ through for the meat to lie flat on the burner and cook evenly. Add mesquite-flavored wood chips to the charcoal for extra flavor.
	Indirect Heat - for remaining 18-20 minutes		
 <b>Pork Chops</b>	Direct Heat	10-15 minutes each side	Choose thick cuts for more tender meat. Trim off excess fat.
 <b>Spare Ribs</b>	Direct Heat - 5 minutes	1.5 - 2 hours turning often	Choose lean meaty ribs. Grill until meat pulls easily from the bone.
	Indirect Heat - to finish		
 <b>Lamb Chops</b>	Direct Heat	25 - 30 minutes each side	Choose thick cuts for more tender meat. Trim off excess fat.
 <b>Hot dogs</b>	Direct Heat	4 – 6 minutes	Select larger wieners and slit lengthwise before grilling.

# Cleaning Instructions

## First time use

1. Wash grids by hand with water and mild dish soap to remove any residue from the manufacturing process. DO NOT wash in a dishwasher.
2. Rinse thoroughly with hot water and dry completely with a soft cloth to prevent moisture from entering the cast iron.

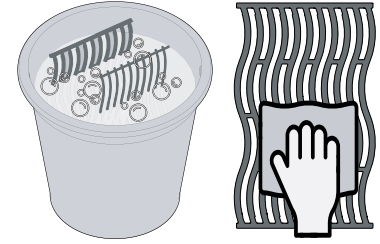

## Cast Iron grids

- Season your grids to add a protective coating to prevent corrosion. See Grilling Tips – **How to Season Cast Iron Cooking Grids.**

## Steel Grids

- Steel cooking grids can be cleaned by preheating the grill and using a wire brush to remove residue.
- Steel grids will permanently discolor from regular use because of high temperatures when grilling.

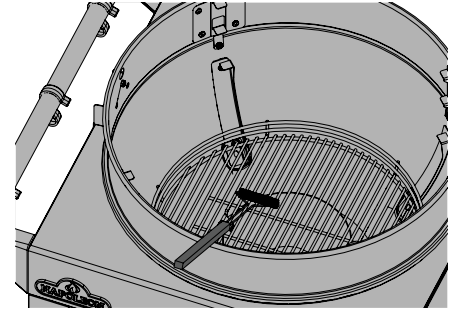

## Inside of the grill

1. Remove the cooking grids.
2. Use a brass wire brush to clean loose debris from the sides and underneath the lid.
3. Scrape all enamel with a plastic putty knife or scraper. Use a wire brush to remove the ash.
4. Sweep debris from inside the grill into the ash pan.
5. Wash the inside of the grill with a mild detergent and water.
6. Rinse well with clear water and wipe dry.

## Disposing of Charcoal and Ash

**WARNING!** Carefully follow these safety precautions to protect yourself and your property from damage.

- Make sure coals and ashes are completely extinguished before removing.
- Use a metal spatula or scoop to remove coals and ashes from grill.
- Place coal and ashes in a non-combustible metal container, and completely saturate with water for 24 hours before disposing.

**WE WANT  
TO HELP!**



Contact the Napoleon  
Customer Solutions  
Department for  
recommended replacement  
parts. +31 345 588655

**WARNING!** Always wear protective gloves and safety glasses when cleaning your grill.

**WARNING!** Accumulated grease is a fire hazard.

**WARNING!** Cleaning should only be done when the grill is cool to avoid the possibility of burns.

**WARNING!** Ensure grill is cool before cleaning. Do not use oven cleaner to clean any part of the grill. Do not put cooking grids or any other parts of the grill in a self-cleaning oven to clean. Clean grill in area where cleaning solution won't harm decks, lawns, or patios.



# Maintenance Instructions

## Ash pan

- Ashes, grease, and excess drippings collect in the ash pan located beneath the charcoal grill and accumulate. Slide the pan free of the grill to clean.
- Never line the inside of the grill with aluminum foil, sand or any other material. This can prevent grease from flowing properly.
- The ash pan should be scraped out with a plastic putty knife or scraper. Brush all debris into a non-combustible metal container.
- Wash the ash pan with mild detergent and water.
- Rinse well with clear water and wipe dry.

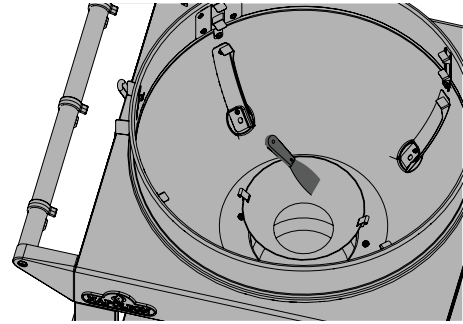

**!** **IMPORTANT!** It is recommended the ash pan be emptied out after each use once the grill cool.

## Hinge adjustment

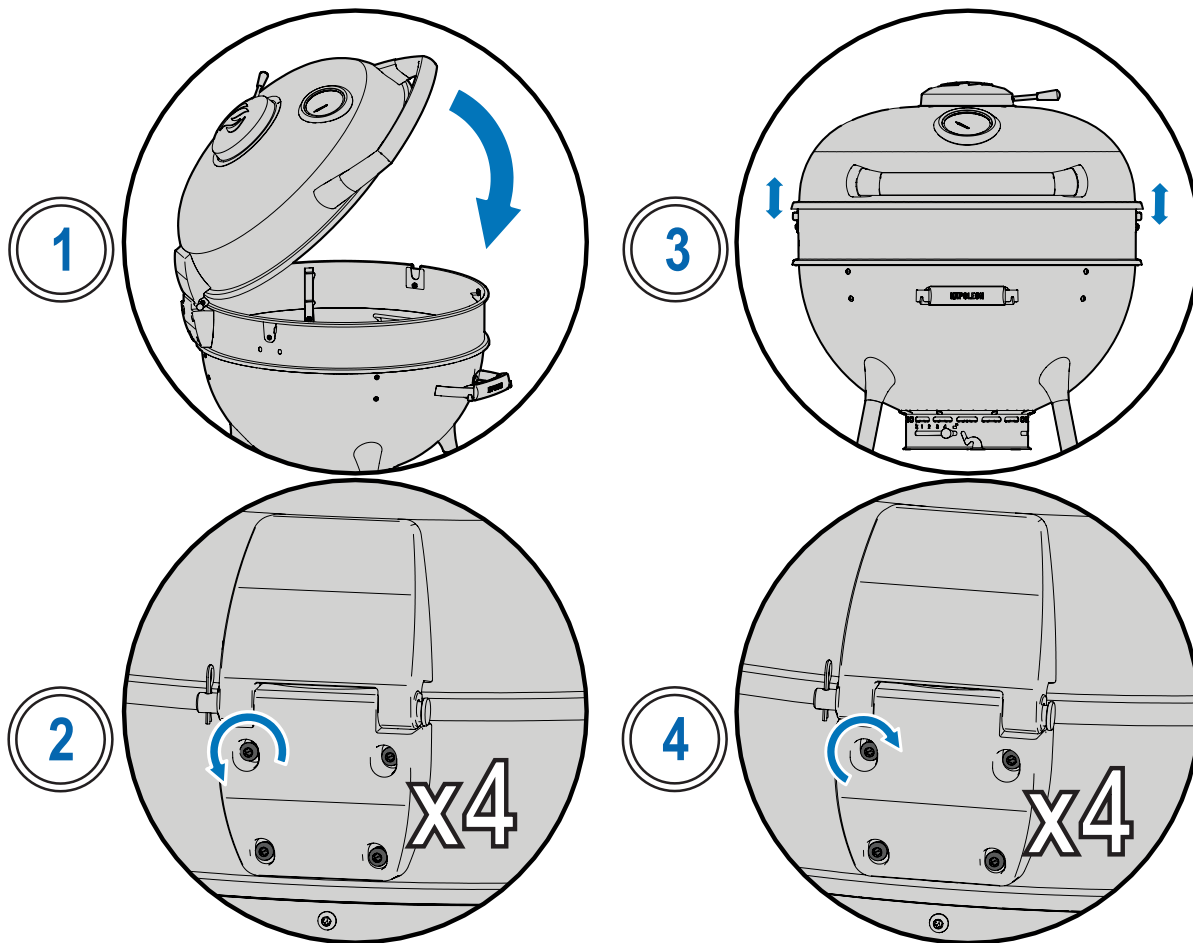

1. Close the lid.
2. Using the T25 Torx key provided, loosen the 4 Torx screws enough that the hinge can move up and down slightly.
3. Make sure the lid is sitting evenly on the stainless riser ring.
4. Retighten the screws using the T25 Torx key.

### Aluminum Castings

Clean with warm soapy water.

Aluminum doesn't rust, but high temperatures and weathering can cause oxidization on the surface of the castings that look like white spots.

### STAINLESS IN HARSH ENVIRONMENTS

Stainless steel oxidizes or stains in the presence of chlorides and sulfides, especially in coastal regions, warm and highly humid areas, and around pools and hot tubs. These stains look like rust, but they can be easily removed or prevented. Wash stainless and chrome surfaces every 3-4 weeks.

Clean with warm soapy water.

### Outside grill surface

- Only use a stainless steel non-abrasive cleaner or water. Abrasive cleaners or steel wool will scratch the finish on any painted, porcelain, or stainless parts of your grill.
- Always wipe in the direction of the grain.
- Handle porcelain enamel components with care.
- The baked-on enamel finish is glass-like and will chip if struck. Touch up enamel is available at your Napoleon Grill dealer.
- Stainless steel parts discolor over time when heated and will turn a golden or brown hue. This is normal and won't affect the performance of the grill.

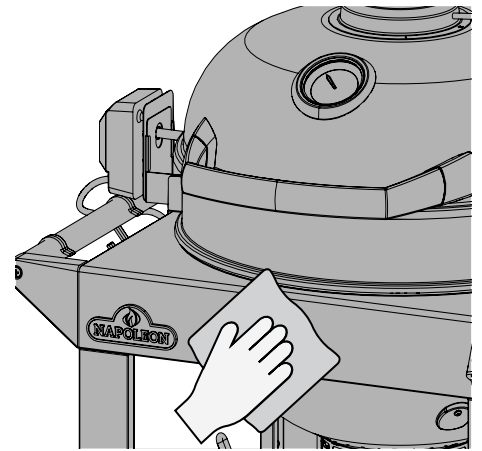

#### SAFETY FIRST!



Always wear protective gloves and safety glasses when servicing your grill.

**WARNING!** Do not use pressure washer or hose to clean any part of the grill.

**WARNING!** Do not use abrasive cleaners or steel wool on any painted, porcelain, or stainless steel parts of your grill.

**WARNING!** Barbecue sauce and salt can be corrosive and will cause rapid deterioration of the grill components unless cleaned regularly.





# Troubleshooting

## Flare-ups and Uneven Heat

- Grill will not light.
- Low heat or low flame.

Possible causes	Solution
Improper preheating.	Allow charcoal to burn until covered with a light gray ash. (Approximately 20 minutes).
Not enough airflow.	Open vents.
Low charcoal.	Add more charcoal to the charcoal tray.
Excessive grease and ash build up in ash/drip pan.	Clean ash/drip pan regularly. Do not line pan with aluminum foil. Refer to <b>“Maintenance Instructions.”</b>

## Peeling paint

- Paint appears to be peeling inside lid or hood.

Possible causes	Solution
Grease build-up on inside surfaces.	This is not a defect. The finish on the lid and hood is porcelain, and will not peel. The peeling is caused by hardened grease, which dries into paint-like shards, that flake off. Regular cleaning will prevent this. See <b>“Maintenance Instructions.”</b>

### WE WANT TO HELP!



Napoleon is here to ensure your grilling experience is memorable. Contact us if you require additional help.

### REGISTER YOUR GRILL!



Register your grill! Go to [Napoleon.com](http://Napoleon.com) or your Assembly Guide for replacement parts instructions.

# NAPOLEON PRODUCT WARRANTY

The present warranty details apply to products purchased after January 1, 2022.

**Refer to your Napoleon Grills Owner's Manual for detailed information on your warranty.**



## FOR THE CHARCOAL KETTLE GRILL SERIES AND APOLLO® SMOKER 10 Years Napoleon Charcoal Grills and Smokers Limited Warranty

NAPOLEON warrants that the components of your new NAPOLEON product will be free from defects in materials and workmanship from the date of purchase for a period of:

Porcelain-enameled lid and bowl .....	10 years
Air control system .....	5 years <sup>plus 10</sup>
Porcelain-enameled cast iron cooking grids .....	5 years <sup>plus 10</sup>
Chromed grill grids .....	3 years <sup>plus 10</sup>
All other parts .....	2 years

**Plus 1d:** refers to an extended warranty period, during which we supply spare parts to the purchaser at 50% of the current retail price for the lifetime\* of the grill.

**Plus 15:** refers to an extended warranty period, during which we supply spare parts to the purchaser at 50% of the current retail price for an additional 15 years.

**Plus 10:** refers to an extended warranty period, during which we supply spare part to the purchaser at 50% of the current retail price for an additional 10 years

**\*Lifetime** refers to a warranty period of 30 years.

**This warranty is valid in:** the European Union, Switzerland, Andorra, San Marino, Norway, Iceland and Liechtenstein.

The customer's legal entitlements in the event of defects in accordance with WKRL - (EU) 2019/711) are not affected, restricted or altered by the present warranty. The exercise of statutory entitlements is to take place free of charge.

### WARRANTY CONDITIONS AND LIMITATIONS

NAPOLEON guarantees that its products are free from defects exclusively to the original purchaser, and only insofar as the purchase took place through an official NAPOLEON dealer. The following conditions and restrictions apply:

The present manufacturer's warranty is not transferable nor viable for extension under any circumstances or by any of our representatives.

The gas grill must be installed by a licensed, authorized service technician or contractor. Installation must take place in accordance with the installation instructions provided, as well as all local and national building and fire codes.

This limited warranty does not cover damage caused by improper operation, lack of maintenance, grease fire,

environmental exposure, accidents, modification, abuse, or neglect. The installation of spare parts from other manufacturers voids the present warranty. The discoloration of plastic elements due to the application of chemical cleaning agents or exposure to sunlight is not covered under this warranty.

This warranty also excludes any of the following: Scratches, dents, paint defects, coatings, corrosion or discoloration caused by exposure to heat or abrasive and chemical cleaners, as well as chips to porcelain-coated parts and any components used in the installation of the gas grill. If a part deteriorates to the point where it becomes inoperable (due to rusting or burning through) within the warranty period, the customer will be issued with a replacement part.

After the first year, NAPOLEON has the authority under this warranty (President's Limited Lifetime Warranty, 15 Year Limited Warranty, 10 Year Limited Warranty, 3 Year Limited Warranty) to waive any warranty obligation at its free discretion by refunding the original purchaser to the tune of the wholesale price of the relevant defective warranty parts.

NAPOLEON accepts no responsibility for any installation, labor hours or other costs or expenses associated with the reinstallation of a warranty part. Costs of this nature are not covered by the present warranty.

Notwithstanding any regulations under this warranty (President's Limited Lifetime Warranty, 15 Year Limited Warranty, 10 Year Limited Warranty, 3 Year Limited Warranty), NAPOLEON's liability under this warranty is defined by the foregoing, and does not cover any incidental, consequential, or indirect damage in any case whatsoever.

This warranty defines NAPOLEON's duties and liability with respect to the NAPOLEON gas grill.

NAPOLEON assumes no further liability in connection with the sale of this product, nor does it authorize any third party to assume any other liability on its behalf.

NAPOLEON assumes no responsibility for: Overheating, extinguishing of the flame by environmental factors such as strong winds or inadequate ventilation.

NAPOLEON does not accept liability for any damage to the gas grill caused by the weather, hail, rough handling, aggressive chemicals or cleaning agents.

Warranty claims must be accompanied by the proof of purchase or a copy thereof stating the serial and model number.

NAPOLEON reserves the right to have the product or any part thereof inspected by one of its representatives prior to the fulfilment of any warranty obligation.

NAPOLEON does not bear shipping costs, labor hours or export duties.

#### **GUARANTOR:**

NAPOLEON EUROPE | WOLF STEEL EUROPE B.V.  
De Riemsdijk 22 | 4004LC | Tiel | Gelderland Netherlands

 +31 345 588 655

 +31 345 588 655

 [de.info@napoleon.com](mailto:de.info@napoleon.com)