

SIU14

SIU14



SIU14

- Motor: **2 x EBM 1100 cfm**
- Pressure: **800 Pa**
- Noise level: **66 dBA/5.1 sones**



- Lighting:
4x20W Halogen lamps in 42" version
6x20W Halogen lamps in 54" version



- Control panel: 4 speed push-button + timer + light switch

- grease filter: commercial style baffle filters
- Stainless steel: AISI 430
- Duct size 8"

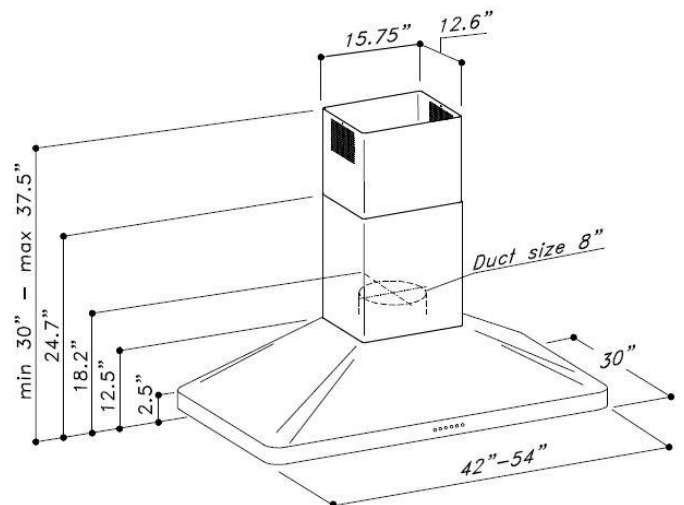

Sirius