

**FEATURES & BENEFITS**



**PERFORMANCE**

- Volume of 5.4 cu ft holds up to 70 bottles (12 oz) or 140 cans (12 oz)
- Digital Touch Pad Control is conveniently located on upper face of unit
- Temperature range: 34°F - 45°F
- Convection cooling system rapidly and efficiently takes items to the set temperature

**INTERIOR/EXTERIOR**

- 32" height meets ADA height requirement yet maximizes allowable space
- White interior is illuminated with LED lighting
- Three adjustable glass shelves
- LowE coated, argon gas filled, dual thermopane glass door provides protection from harmful UV Light
- Stainless steel handle (7/8" diameter)
- Door swing is field reversible, and is shipped right-hand hinged
- Door lock is standard on stainless and black models

**INTEGRATION**

- Unit is designed to be built-in or can be freestanding
- Four independently adjustable leveling legs provide a precise undercounter fit
- Available in the following finishes: Stainless, Integrated, or Black
- Integrated model requires 3/4" custom door panel (panels not supplied by U-Line)



STAINLESS  
FRAME (LOCK)



INTEGRATED  
FRAME



BLACK  
FRAME (LOCK)

**Model Details**

Model	Voltage/Hz	Door Swing	Finish	Shipping Weight
U-ADA24RGLS-13B	115 / 60	Field Reversible	Stainless Frame (Lock)	128 lb
U-ADA24RGLINT-00A	115 / 60	Field Reversible	Integrated Frame	122 lb
U-ADA24RGLB-13B	115 / 60	Field Reversible	Black Frame (Lock)	128 lb

## DIMENSIONS

Dimensions shown apply to all finishes, including Integrated (INT) models with 3/4" integrated panel/frame installed.

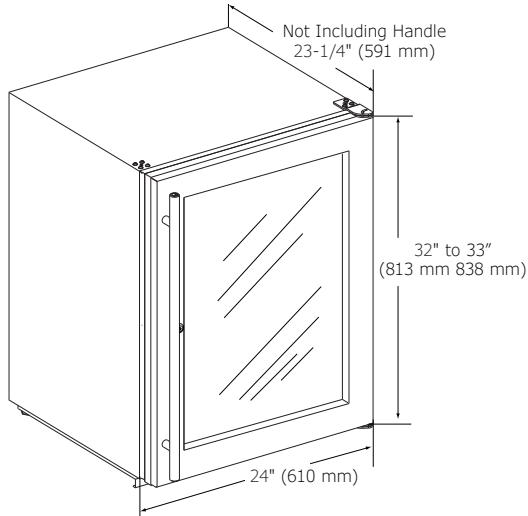

## CABINET CUT-OUT

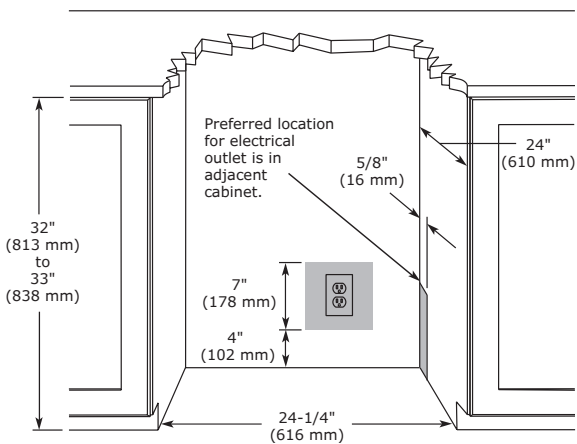

## INSTALLATION NOTES

When installing adjacent to wall, ensure 2 1/2" clearance on hinged side for 90° door opening, allowing ample room for door handle.

Cutout includes the additional 1/4" width overall to ensure proper installation.

No additional clearance around sides, top or rear of unit is needed for ventilation.

Do not obstruct front grille air flow.

- 1 Year (parts & labor) / 5 year sealed system (parts)
- + **Additional 1 Year (parts & labor) warranty at no cost with product registration**

See complete warranty for details

## SPECIFICATIONS

Model	ADA24RGL
Amps: Running	1.2
Capacity: Bottle (12 oz)	70
Capacity: Can (12 oz)	140
Capacity: Volume (cu ft)	5.4
Control Type	Digital Touch Pad
Dimensions: Product Depth	23 1/4" / 591 mm
Dimensions: Product Height	32" / 813 mm
Dimensions: Product Width	24" / 610 mm
Energy Consumption: Avg. Per Year	300 kWh
ENERGY STAR	No
Panel Height	30 1/4" / 768 mm
Panel Thickness	3/4" / 20 mm
Panel Type	2 3/4" / 70 mm Frame Panel
Panel Width	23 3/4" / 603 mm
Product Weight: Max	122 lb
Refrigerant Type	R600a (1.23 oz)
Sabbath (Star K Certified)	Yes
Temperature Range	34°F - 45°F

## COOLING SYSTEM

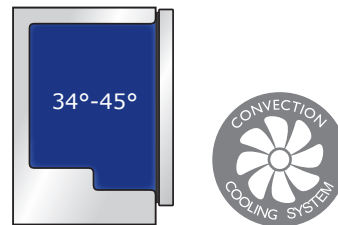

## ELECTRICAL REQUIREMENTS

This unit requires a grounded, polarized 115 VAC, 60 Hz, 15 A power supply (normal household current).

