



FEATURES & BENEFITS



STAINLESS
SOLID (LOCK)



INTEGRATED
SOLID



BLACK
SOLID (LOCK)

PERFORMANCE	<ul style="list-style-type: none"> • Volume of 5.3 cu ft holds up to 70 bottles (12 oz) or 140 cans (12 oz) • Digital Touch Pad Control is conveniently located on upper face of unit • Temperature range: 34°F - 45°F • Convection cooling system rapidly and efficiently takes items to the set temperature
INTERIOR/EXTERIOR	<ul style="list-style-type: none"> • 32" height meets ADA height requirement yet maximizes allowable space • White interior is illuminated with LED lighting • Three adjustable glass shelves • Stainless steel handle (7/8" diameter) • Door swing is field reversible, and is shipped right-hand hinged • Door lock is standard on stainless and black models
INTEGRATION	<ul style="list-style-type: none"> • Unit is designed to be built-in or can be freestanding • Four independently adjustable leveling legs provide a precise undercounter fit • Available in the following finishes: Stainless, Integrated, or Black • Integrated model requires 3/4" custom door panel (panels not supplied by U-Line)

Model Details

Model	Voltage/Hz	Door Swing	Finish	Shipping Weight
U-ADA24RS-13B	115 / 60	Field Reversible	Stainless Solid (Lock)	123 lb
U-ADA24RINT-00A	115 / 60	Field Reversible	Integrated Solid	117 lb
U-ADA24RB-13B	115 / 60	Field Reversible	Black Solid (Lock)	123 lb

DIMENSIONS

Dimensions shown apply to all finishes, including Integrated (INT) models with 3/4" integrated panel/frame installed.

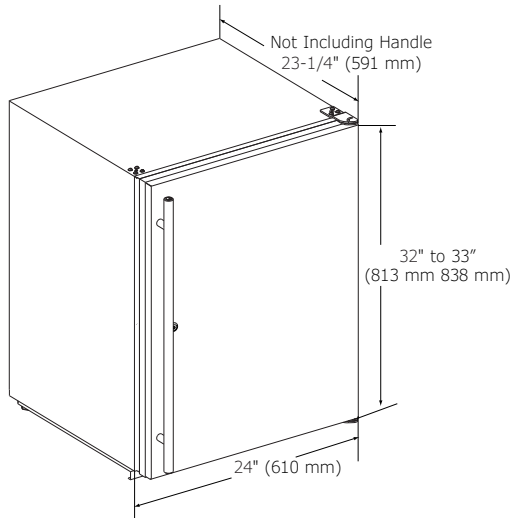

CABINET CUT-OUT

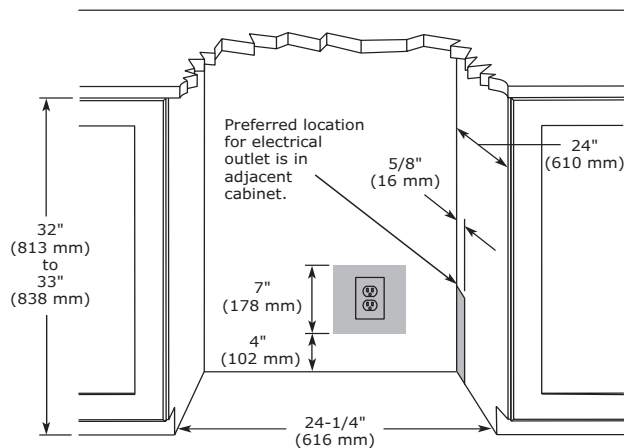

INSTALLATION NOTES

When installing adjacent to wall, ensure 2 1/2" clearance on hinged side for 90° door opening, allowing ample room for door handle.

Cutout includes the additional 1/4" width overall to ensure proper installation.

No additional clearance around sides, top or rear of unit is needed for ventilation.

Do not obstruct front grille air flow.

- 1 Year (parts & labor) / 5 year sealed system (parts)
- + **Additional 1 Year (parts & labor) warranty at no cost with product registration**

See complete warranty for details

SPECIFICATIONS

Model	ADA24R
Amps: Running	1.2
Capacity: Bottle (12 oz)	70
Capacity: Can (12 oz)	140
Capacity: Volume (cu ft)	5.3
Control Type	Digital Touch Pad
Dimensions: Product Depth	23 1/4" / 591 mm
Dimensions: Product Height	32" / 813 mm
Dimensions: Product Width	24" / 610 mm
Energy Consumption: Avg. Per Year	240 kWh
ENERGY STAR / CEE RATING	ENERGY STAR / Tier 3
Panel Height	30 1/4" / 768 mm
Panel Thickness	3/4" / 20 mm
Panel Type	Solid Panel
Panel Width	23 3/4" / 603 mm
Product Weight: Max	117 lb
Refrigerant Type	R600a (1.23 oz)
Sabbath (Star K Certified)	Yes
Temperature Range	34°F - 45°F

COOLING SYSTEM



ELECTRICAL REQUIREMENTS

This unit requires a grounded, polarized 115 VAC, 60 Hz, 15 A power supply (normal household current).

