

ZEPHYR

WWW.ZEPHYRONLINE.COM

Venezia

ZVE-E30DS, ZVE-E36DS, ZVE-E42DS

EN Use, Care, and Installation Guide

FR Guide d'utilisation, d'entretien et d'installation

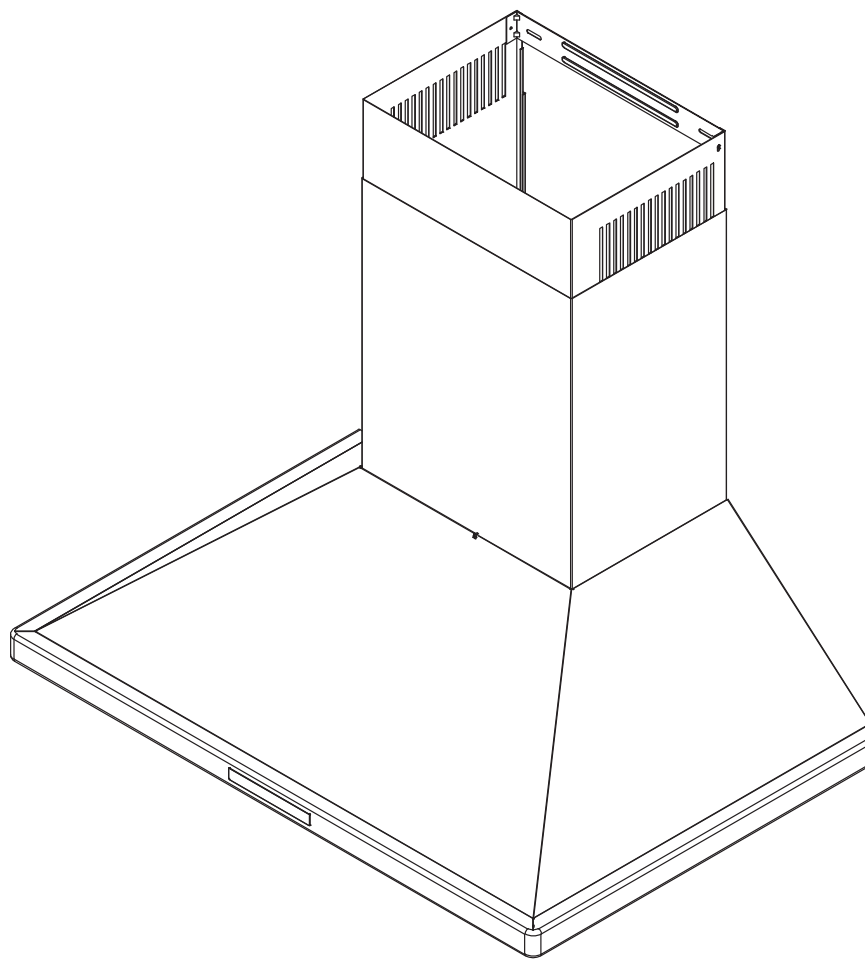

	Page
Safety Information	4-6
Types of Safety Warnings.....	4
General Safety	4-5
Operation	6
Electrical Requirements	6
Federal Communication Commission Interface Statement	6
List of Materials.....	7
Installation Instructions.....	8-17
Ducting Calculation Sheet.....	8
Mounting Height, Clearance, & Ducting	9-10
Ducting Options	11
Hood Specifications.....	12
Electrical Supply.....	13
Cable Lock	13
Mounting the Hood.....	14-15
Ductless Recirculation	16-17
Features & Controls.....	18-24
Proximity Controls	18-20
Zephyr Connect	21-22
Optional RF Remote Control.....	23-24
Maintenance	25-27
Hood & Filter Cleaning.....	25-26
LumiLight LED	27
ACT™ Conversion.....	28-30
Airflow Control Technology (ACT™)	28
Enabling ACT™	29-30
Wiring Diagram	31
Troubleshooting.....	32-34
List of Parts & Accessories	35
Notes.....	36
Limited Warranty	37
Product Registration.....	38

Safety Information

READ AND SAVE THESE INSTRUCTIONS

Your safety and the safety of others are very important. We have provided many important safety messages in this manual for your appliance. Always read and obey all safety messages.



This is the Safety Alert Symbol. This symbol alerts you to potential hazards that can cause severe bodily injury or death. All safety messages will follow the Safety Alert Symbol and either the words “DANGER” “WARNING” or “CAUTION”



General Safety



WARNING - TO REDUCE THE RISK OF FIRE, ELECTRIC SHOCK, OR INJURY TO PERSONS, OBSERVE THE FOLLOWING:

- Use this unit only in the manner intended by the manufacturer. If you have questions, contact the manufacturer.
- Before servicing or cleaning unit, switch power off at service panel and lock the service disconnecting means to prevent power from being switched on accidentally. When the service disconnecting means cannot be locked, securely fasten a prominent warning device, such as a tag, to the service panel.



WARNING - TO REDUCE THE RISK OF A RANGE TOP GREASE FIRE:

- Never leave surface units unattended at high settings. Boilovers cause smoking and greasy spillovers that may ignite. Heat oils slowly on low or medium settings.
- Always turn hood ON when cooking at high heat or when flambeing food. (i.e. Crepes Suzette, Cherries Jubilee, Peppercorn Beef Flambe’).
- Clean ventilating fans frequently. Grease should not be allowed to accumulate on fan or filter.
- Use proper pan size. Always use cookware appropriate for the size of the surface element.

READ AND SAVE THESE INSTRUCTIONS



WARNING - TO REDUCE THE RISK OF INJURY TO PERSONS IN THE EVENT OF A RANGE TOP GREASE FIRE, OBSERVE THE FOLLOWING^o:

- a) SMOTHER FLAMES with a close-fitting lid, cookie sheet, or metal tray, then turn off the burner. BE CAREFUL TO PREVENT BURNS. If the flames do not go out immediately, EVACUATE AND CALL THE FIRE DEPARTMENT.
- b) NEVER PICK UP A FLAMING PAN – You may be burned.
- c) DO NOT USE WATER, including wet dishcloths or towels – a violent steam explosion will result.
- d) Use an extinguisher ONLY if:
 - 1) You know you have a Class ABC extinguisher, and you already know how to operate it.
 - 2) The fire is small and contained in the area where it started.
 - 3) The fire department is being called.
 - 4) You can fight the fire with your back to an exit

^oBased on “Kitchen Firesafety Tips” published by NFPA.



WARNING - TO REDUCE THE RISK OF FIRE, ELECTRIC SHOCK, OR INJURY TO PERSONS, OBSERVE THE FOLLOWING:

- a) Installation work and electrical wiring must be done by qualified person(s) in accordance with all applicable codes and standards, including fire-rated construction.
- b) Sufficient air is needed for proper combustion and exhausting of gases through the flue (chimney) of fuel burning equipment to prevent back drafting. Follow the heating equipment manufacturer’s guideline and safety standards such as those published by the National Fire Protection Association (NFPA), and the American Society for Heating, Refrigeration and Air Conditioning Engineers (ASHRAE), and the local code authorities.
- c) When cutting or drilling into wall or ceiling, do not damage electrical wiring and other hidden utilities.
- d) Ducted fans must always be vented to the outdoors.
- e) If this unit is to be installed over a tub or shower, it must be marked as appropriate for the application and be connected to a GFCI (Ground Fault Circuit Interrupter) - protected branch circuit.



Safety Information

READ AND SAVE THESE INSTRUCTIONS

Operation

- ▶ Always leave safety grilles and filters in place. Without these components, operating blowers could catch onto hair, fingers and loose clothing.
- ▶ The manufacturer declines all responsibility in the event of failure to observe the instructions given here for installation, maintenance and suitable use of the product. The manufacturer further declines all responsibility for injury due to negligence and the warranty of the unit automatically expires due to improper maintenance.

NOTE: Please check www.zephyronline.com for revisions before doing any custom work.

Electrical Requirements

Important:

- ▶ Observe all governing codes and ordinances.
- ▶ It is the customer's responsibility to be aware of these below:
- ▶ To contact a qualified electrical installer.
- ▶ To assure that the electrical installation is adequate and in conformance with National Electrical Code, ANSI/NFPA 70 latest edition* or CSA standards C22.1-94, Canadian Electrical Code, Part 1 and C22.2 No.0-M91 - latest edition** and all local codes and ordinances.
- ▶ If codes permit and a separate ground wire is used, it is recommended that a qualified electrician determine that the ground path is adequate.
- ▶ Do not ground to a gas pipe.
- ▶ Check with a qualified electrician if you are not sure the range hood is properly grounded.
- ▶ Do not have a fuse in the neutral or ground circuit.
- ▶ This appliance requires a 120V 60Hz electrical supply and connected to an individual properly grounded branch circuit protected by a 15 or 20 ampere circuit breaker or time delay fuse. Wiring must be 2 wire with ground. Please also refer to Electrical Diagram on product.
- ▶ A cable locking connector (not supplied) might also be required by local codes. Check with local requirements, purchase and install appropriate connector if necessary.

* National Fire Protection Association Batterymarch Park, Quincy, Massachusetts 02269

** CSA International 8501 East Pleasant Valley Road, Cleveland, Ohio 44131-5575

Federal Communication Commission Interface Statement

- ▶ This equipment has been tested and found to comply with the limits for a Class B digital device, pursuant to Part 15 of the FCC Rules. These limits are designed to provide reasonable protection against harmful interference in a residential installation.
- ▶ This equipment generates, uses and can radiate radio frequency energy and, if not installed and used in accordance with the instructions, may cause harmful interference to radio communications. However, there is no guarantee that interference will not occur in a particular installation. If this equipment does cause harmful interference to radio or television reception, which can be determined by turning the equipment off and on, the user is encouraged to try to correct the interference by one of the following measures:
- ▶ Reorient or relocate the receiving antenna.
- ▶ Increase the separation between the equipment and receiver.
- ▶ Connect the equipment into an outlet on a circuit different from that to which the receiver is connected.
- ▶ Consult the dealer or an experienced radio/TV technician for help.

Parts Supplied

Quantity	Part
1	Hood
2	Hybrid baffle filters
2	LumiLight LED, 6W (pre-installed)
1	Duct cover assembly (top and bottom)
1	Duct cover wall bracket
1	8" round backdraft damper (pre-installed)
1	Hardware package

M4 x 8" (2)

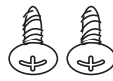

M4 x 1-1/4" (3)

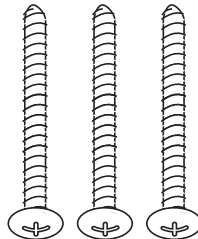

#6 x 1" (2)

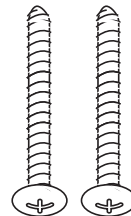

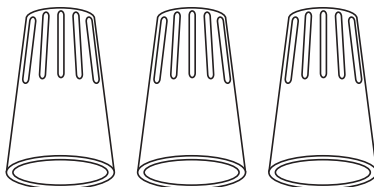

Wire Nuts (3)

**Parts Not Supplied**

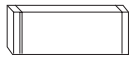
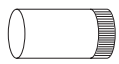
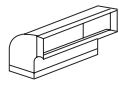
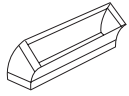
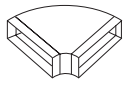
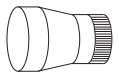
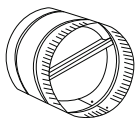

Ducting, conduit and all installation tools
Cable locking connector (if required by local codes)
Duct cover extension accessory (Z1C-01VE)
Recirculating kit (ZRC-03VE)
RF remote control (14000005)

Installation Instructions

Ducting Calculation Sheet

Duct pieces		Equivalent number length x used =	Total
	3-1/4" x 10" Rect., straight	1 Ft. x () =	Ft.
	6", 7", 8", 10" Round, straight	1 Ft. x () =	Ft.
	3-1/4" x 10" Rect. 90° elbow	15 Ft. x () =	Ft.
	3-1/4" x 10" Rect. 45° elbow	9 Ft. x () =	Ft.
	3-1/4" x 10" Rect. 90° flatelbow	24 Ft. x () =	Ft.
	7" to 6" or 8" to 7" Round tapered reducer	25 Ft. x () =	Ft.
	6", 7", 8" Round in-line damper	15 Ft. x () =	Ft.
	6", 7", 8", 10" Round, 90° elbow	15 Ft. x () =	Ft.
	6", 7", 8", 10" Round, 45° elbow	9 Ft. x () =	Ft.
Subtotal column 1 =			Ft.

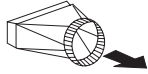
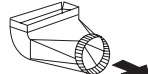
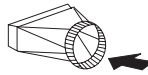
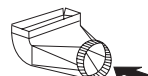
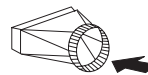
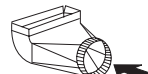
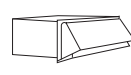
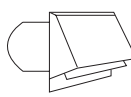
Maximum Duct Length: For satisfactory air movement, the total duct length should not exceed 150 equivalent feet.

Duct pieces		Equivalent number length x used =	Total
	3-1/4" x 10" Rect. to 6" round transition	5 Ft. x () =	Ft.
	3-1/4" x 10" Rect. to 6" round transition 90° elbow	20 Ft. x () =	Ft.
	6" round to 3-1/4" x 10" rect. transition	1 Ft. x () =	Ft.
	6" round to 3-1/4" x 10" rect. transition 90° elbow	16 Ft. x () =	Ft.
	7" round to 3 1/4" x 10" rect. transition	8 Ft. x () =	Ft.
	7" round to 3-1/4" x 10" rect. transition 90° elbow	23 Ft. x () =	Ft.
	3-1/4" x 10" Rect. wall cap with damper	30 Ft. x () =	Ft.
	6", 7", 8", 10" Round, wall cap with damper	30 Ft. x () =	Ft.
	6", 7", 8", 10" Round roof cap	30 Ft. x () =	Ft.
Subtotal column 2 =			Ft.
Subtotal column 1 =			Ft.
Total ductwork =			Ft.

Mounting Height, Clearance, & Ducting

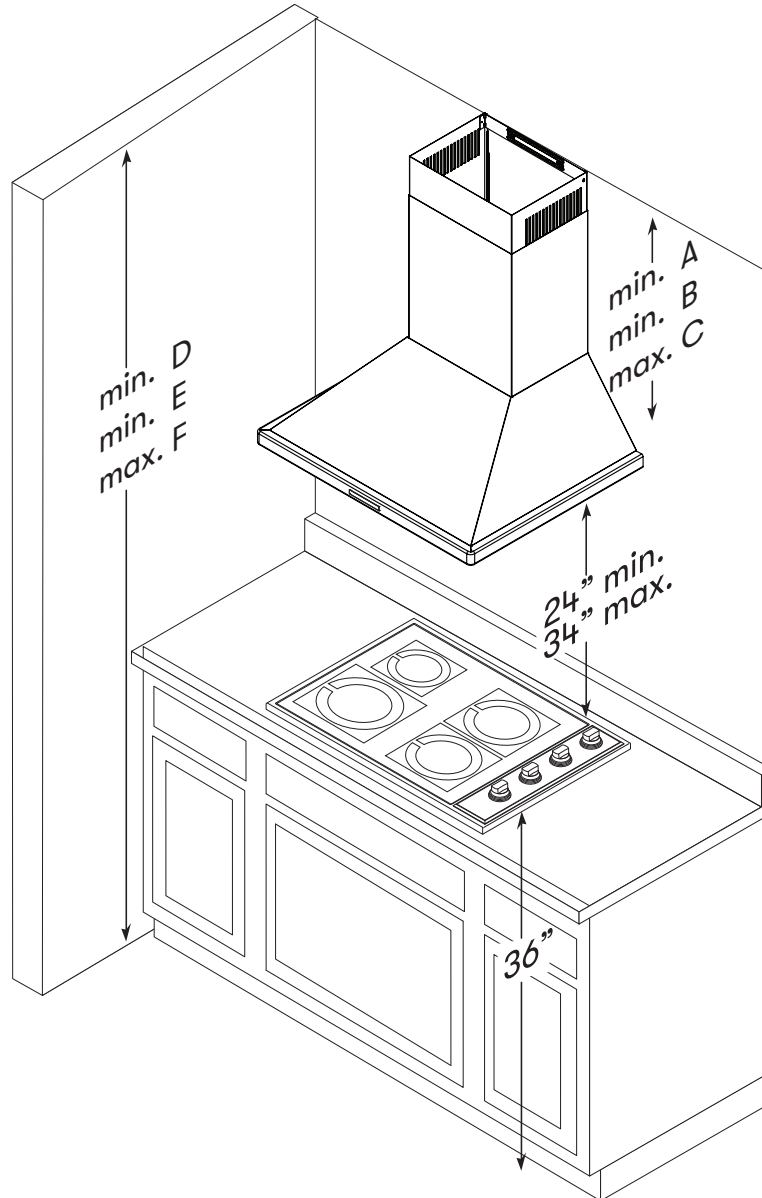

Hood Heights	Standard Duct Cover	Extension Duct Cover
minimum ducted (A)	27"	45"
minimum recirculating (B)	31-1/2"	49-1/2"
maximum (C)	44"	80"
Ceiling Heights		
minimum ducted (D)	87" (7' 3")	105" (8' 9")
minimum recirculating (E)	91-1/2" (7' 7-1/2")	109-1/2" (9' 1-1/2")
maximum (F)	114" (9' 6")	150" (12' 6")

Installation Instructions

Mounting Height, Clearance, & Ducting

A minimum of 8" round duct is recommended to maintain maximum air flow efficiency.

Always use rigid type metal ducts only. Flexible ducts could restrict air flow by up to 50%.

Also use the ducting calculation sheet (on page 11) to compute total available duct run when using elbows, transitions and caps.

ALWAYS, when possible, reduce the number of transitions and turns. If long duct run is required, increase duct size from 8" to 10".

If turns or transitions are required; install as far away from hood duct output and as far apart, between the two as possible.

Minimum mount height between range top to hood bottom should be no less than 24".

Maximum mount height should be no higher than 34".

It is important to install the hood at the proper mounting height. Hoods mounted too low could result in heat damage and fire hazard; while hoods mounted too high will be hard to reach and will lose its performance and efficiency.

If available, also refer range manufacturer's height clearance requirements and recommended hood mounting height above range. Always check your local codes for any differences.

Duct cover extension kit available for ceiling heights up to 12 feet. Turn to the list of parts and accessories section for part number and ordering information.

For shipment and installation damages:

- ▶ Please fully inspect unit for damage before installation.
- ▶ If the unit is damaged in shipment, return the unit to the store in which it was bought for repair or replacement.
- ▶ If the unit is damaged by the customer, repair or replacement is the responsibility of the customer.
- ▶ If the unit is damaged by the installer (if other than the customer), repair or replacement must be made by arrangement between customer and installer.

Ducting Options



WARNING



Fire Hazard: NEVER exhaust air or terminate ductwork into spaces between walls, crawl spaces, ceilings, attics, or garages. All exhaust must be ducted to the outside, unless using the recirculating option.

- ▶ Use single wall rigid metal ductwork only.
- ▶ Fasten all connections with sheet metal screws and tape all joints w/ certified Silver Tape or Duct Tape.

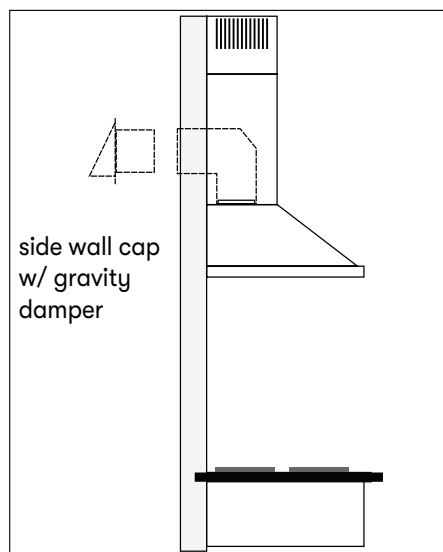
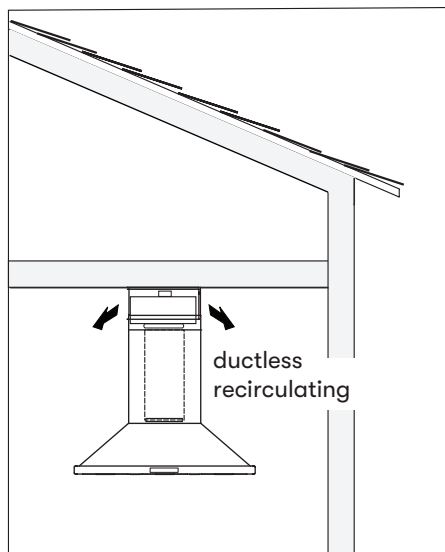
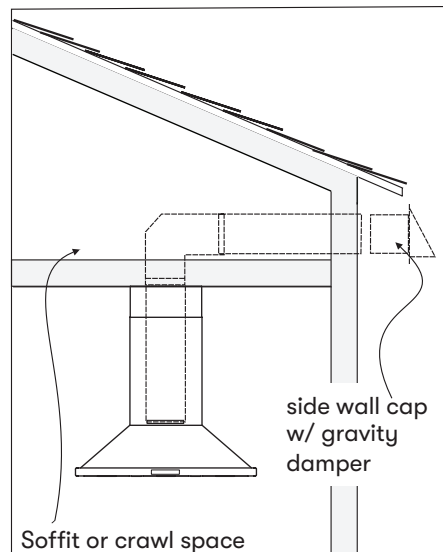
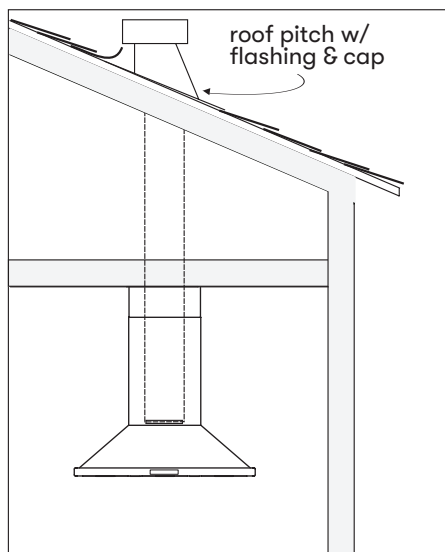

Installation Instructions

Hood Specifications

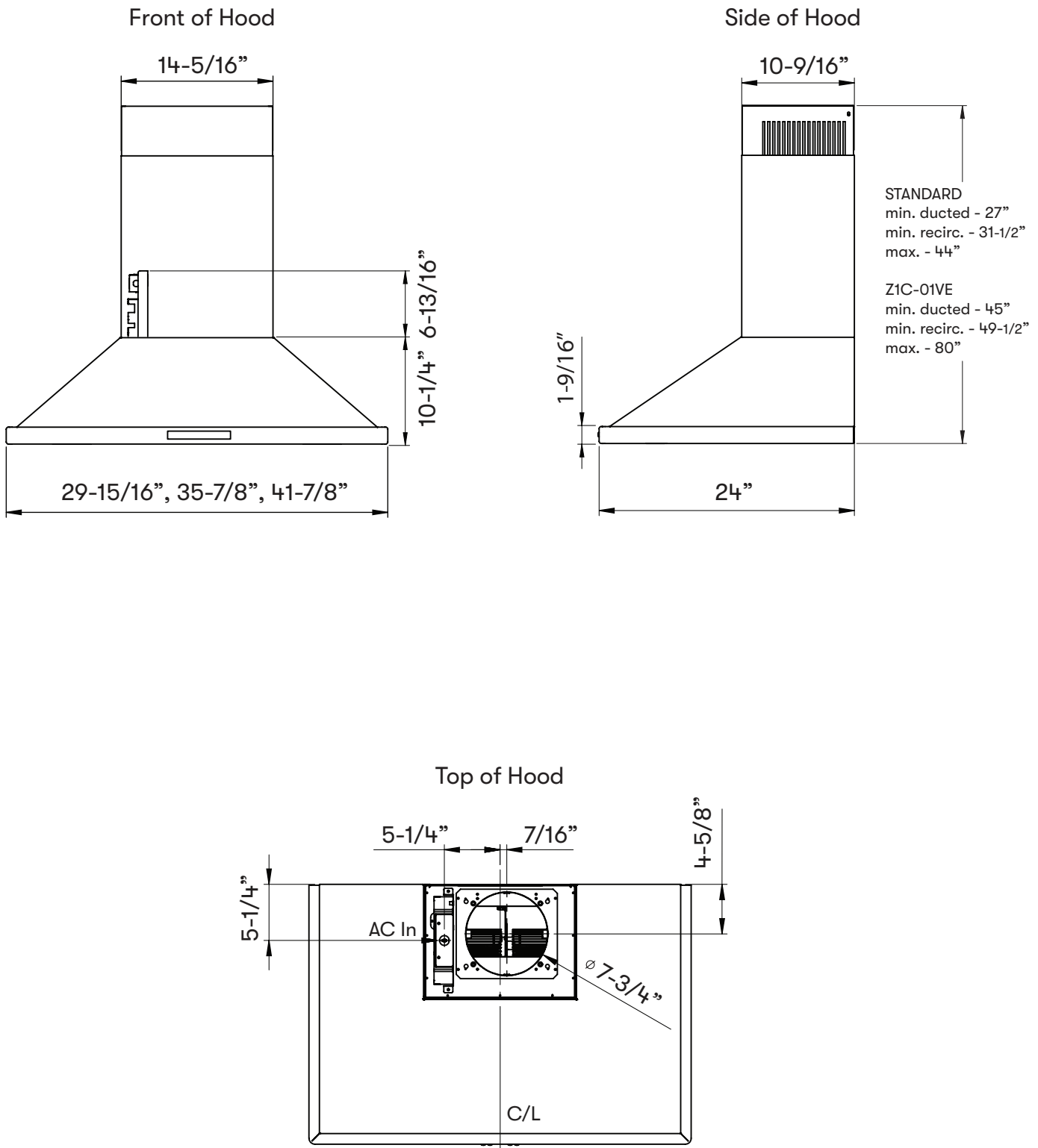

Electrical Supply

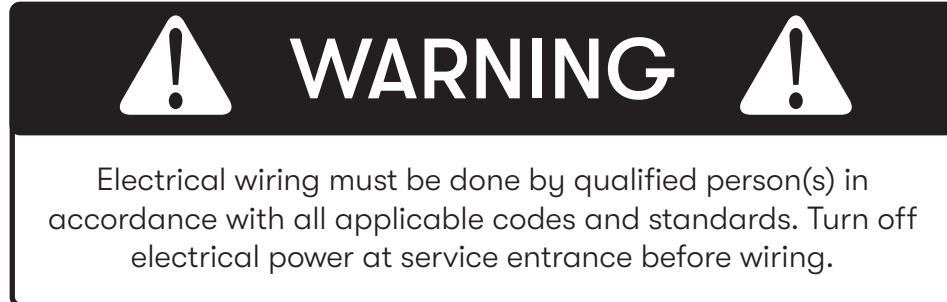

For personal safety, remove house fuse or open circuit breaker before beginning installation. Do not use extension cord or adapter plug with this appliance.

Follow national electrical codes or prevailing local codes and ordinances.

This appliance requires a 120V 60Hz electrical supply, and connected to an individual, properly grounded branch circuit, protected by a 15 or 20 ampere circuit breaker or time delay fuse. Wiring must be 2 wire w/ ground. Please also refer to the Electrical Diagram labeled on product.

Cable Lock

A cable locking connector (not supplied) might be required by local codes. Check with local requirements and codes, purchase and install appropriate connector if necessary. (FIG. A)

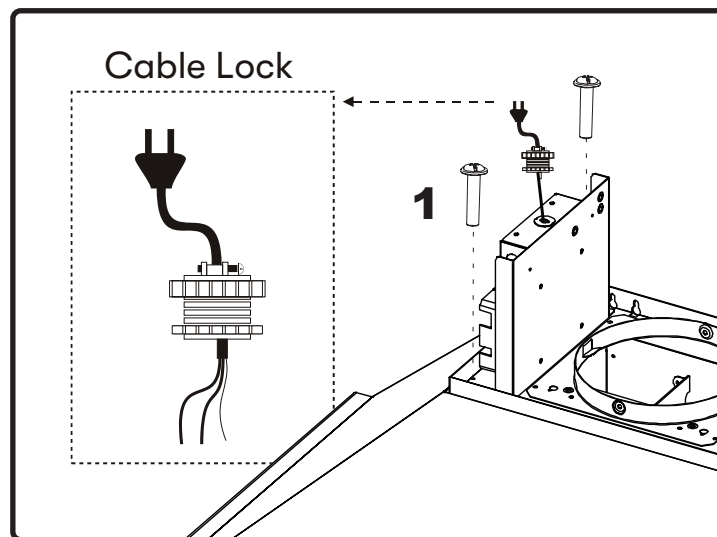

FIG. A

Installation Instructions

Mounting the Hood



CAUTION

At least two installers are required due to the weight and size of the hood.

1. Measure from range top to hood bottom and mark line A. (24" minimum from range top).
2. Plum and mark center line.
3. Mark mounting height line B. (10-1/4" from line A)
4. Mark mounting spread from C/L on line B. From center line to left mount mark (3-9/16"). From center line to right mount mark (4-3/4")



WARNING

Wood blocking may need to be added behind the drywall if no studs are present. Wall anchors may also be used but check local codes for compliance. Failure to use suitable wall anchors and screws to hold the weight of the hood could result in personal injury or damage to cooking surface or counter.

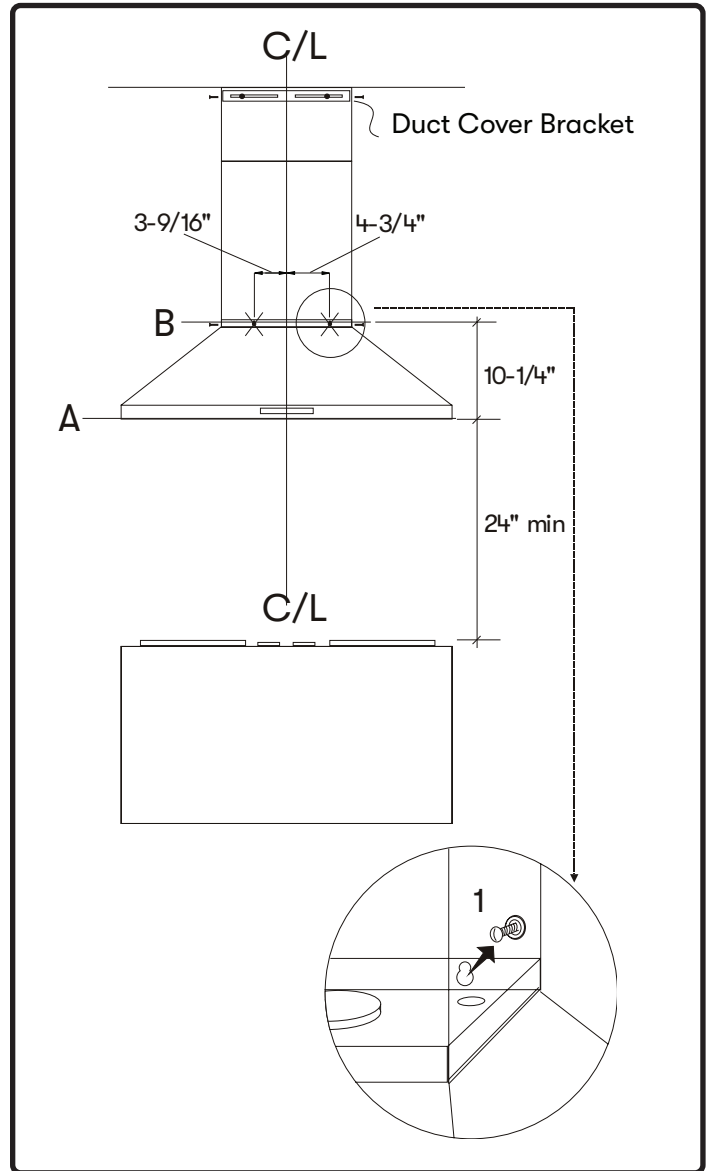

FIG. B

5. Fasten (2) M4 x 1-1/4" screws into studs on line B. Do not fasten screws all the way.
6. Hang hood onto screws and hand tighten. (FIG. B1) Use the last M4 x 1-1/4" screw to further secure the hood to the wall from inside the hood.
7. Center and attach duct cover bracket to wall below ceiling or soffit using (2) #6 x 1" screws.
8. Remove tape securing electronics mounting bracket to hood. Reposition electronics mounting bracket to hood and secure by two pre-installed screws as shown in (FIG. A1).
9. Install electrical.

Mounting the Hood

10. Install duct work and duct tape.
11. Unwrap the blue antenna wire and position it behind the duct cover from step 13. There is no need to secure it.
12. Power up hood and check for leaks around duct tape.
13. Place telescopic duct covers onto hood and extend inner (top) duct cover upwards and secure to duct cover bracket using (2) M4 x 8" screws.

NOTE: If using hood in recirculating mode you must secure the air diverter plate onto wall before installing duct work and duct covers. Turn to page 19 for more details.

Installation Instructions

Ductless Recirculation

Ductless recirculation is intended for applications where an exhaust duct work is not possible to be installed. When converted, the hood functions as a recirculating hood rather than an exhaust hood. Fumes and exhaust from cooking are drawn and filtered by a set of optional charcoal filters. The air is then purified and re-circulated back within the home.

We recommend to ALWAYS exhaust air outside of the home by employing existing or installing new duct work, if possible. The hood is most effective and efficient as an exhaust hood. Only when the exhaust option is not possible should you recourse to converting the hood into a recirculating hood.

When converted to be a recirculating hood, a set of charcoal filters are required on top of its standard Metal Filter set. Order according to its part number below. The standard mesh filters are intended to capture residue from cooking, and the optional charcoal filters help to purify fumes exhausted from cooking for recirculation.

Recirculating Kit Installation (required if no ducting is used)

Kit includes the charcoal filters and the air diverter plate.

Hood Model	Part Number	Filters in Package
ZVE-E30DS	ZRC-03VE	2
ZVE-E36DS	ZRC-03VE	2
ZVE-E42DS	ZRC-03VE	2

1. Purchase recirculating kit per the part number above.
2. Secure air diverter plate to wall below duct cover bracket. (FIG. C) Run 8" ducting from top of hood and secure to air diverter plate. See manual included with recirculating kit for more detailed instructions.
3. Remove hybrid baffle filters from hood. Place the charcoal filters to the back side of the hybrid baffle filters. Secure the charcoal filters in place with rubber clips. (FIG. C).
4. Re-install hybrid baffle filters.

5. Enable recirculating mode on the proximity controls. (Refer details to pg. 20)
6. Charcoal filters must be replaced after every 200 hours of use (or approximately every 3 to 6 months based on the average of 1 - 2 hours of daily cooking time). After 200 hours of use, the notification bell icon will display. When the bell is tapped, the LCD display will cycle between showing "REPLACE CHARCOAL FLTR" and "HOLD UP TO RESET" every 2 seconds.

Charcoal Filter Replacements

Hood Model	Part Number	Quantity to Order
ZVE-E30DS	ZOF-C005	2
ZVE-E36DS	ZOF-C005	2
ZVE-E42DS	ZOF-C005	2

DO NOT WASH CHARCOAL FILTERS. Charcoal filters may need to be changed more often depending on cooking habits.

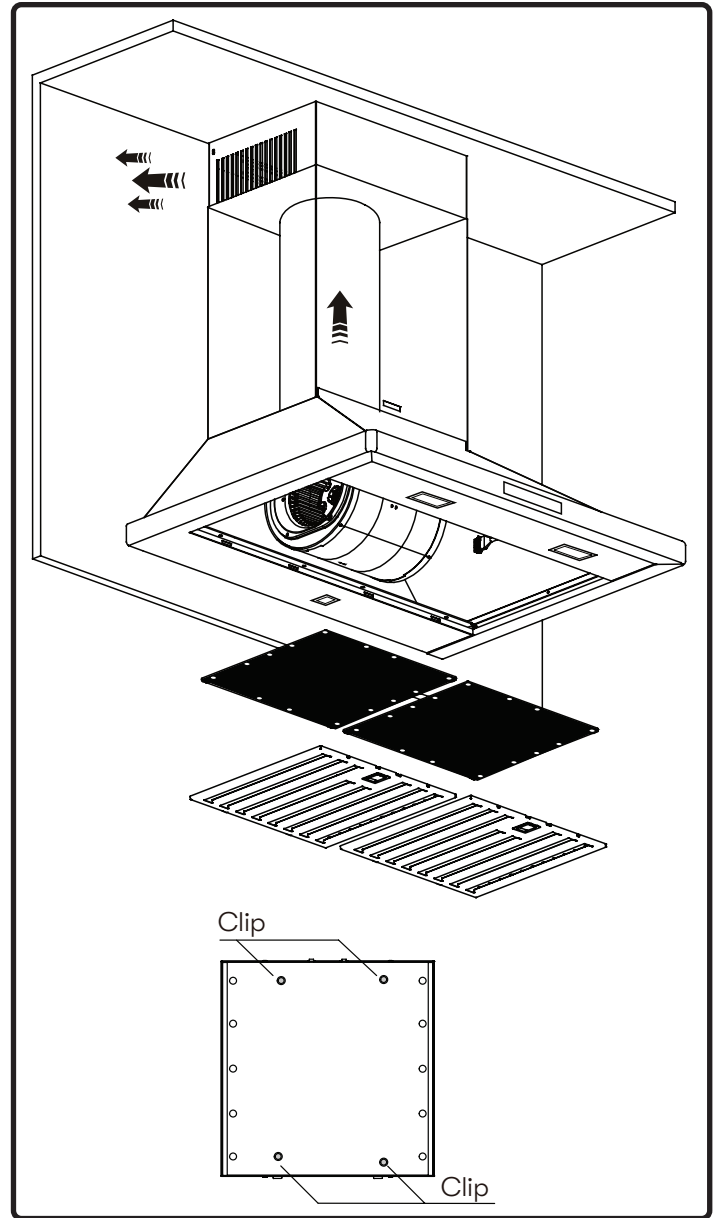
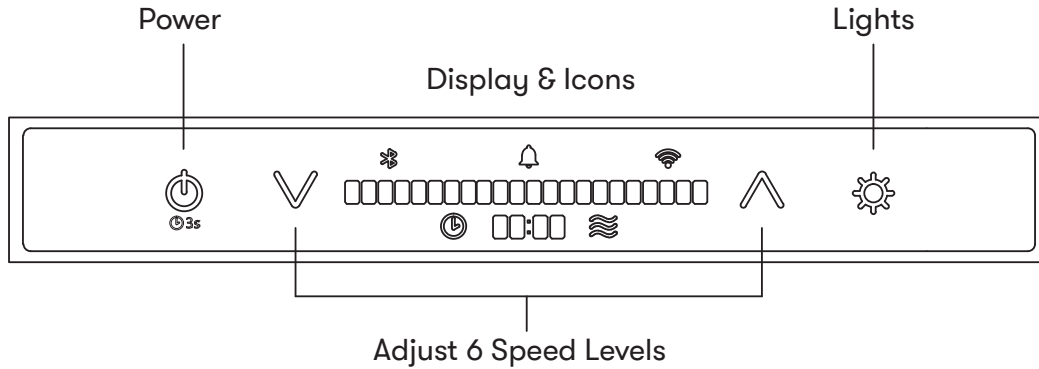

FIG. C

Features & Controls

Proximity Controls



PROXIMITY SENSOR

- ▶ When approaching the hood while it is powered off, the Power, Fan Decrease, Fan Increase, and Light icons will illuminate, and “HELLO” will appear on the LCD display for 2 seconds.
- ▶ If neither the fan nor lights are turned on within 60 seconds, the icons will turn off, and “GOODBYE” will appear on the LCD display for 2 seconds.
 - ▶ The icons will not disappear until the fan and lights are turned off.

CONTROL ICONS

Power

- ▶ Press the power icon to power on or off the fan and lights.
- ▶ The hood has a memory function to remember the last used settings for the fan and lights.
- ▶ After pressing the power icon to power off the hood, “GOODBYE” will appear on the LCD display for 2 seconds.
 - ▶ The 3s icon under the power icon only illuminates when the fan is powered on. It is an indicator to enable Automatic Delay Off by pressing and holding the power button for 3 seconds.

Decrease Fan Speed

- ▶ Press the icon to decrease fan speed from 6, 5, 4, 3, 2, 1, off.

Increase Fan Speed

- ▶ Press the icon to increase fan speed from off, 1, 2, 3, 4, 5, 6.

Lights

- ▶ Press the lights icon to change lighting level from 1, 2, 3, off.

Proximity Controls

DISPLAY ICONS & FUNCTIONS

Notification Bell

- ▶ The notification bell icon will illuminate when an action needs to be taken. Tapping the icon will cycle through the notifications. The notification bell will remain illuminated until all notifications are resolved. The notification bell will not illuminate when the hood and controls are powered off.

Bluetooth®

- ▶ The Bluetooth® icon will illuminate the device when connected with the hood via Bluetooth®. The words “BLUETOOTH CONNECTED” or “BLUETOOTH DISCONNECT” will appear on the LCD display whenever the connection changes.



Wi-Fi

- ▶ The Wi-Fi icon will illuminate when the hood is connected to the Wi-Fi. The words “WIFI CONNECTED” or “WIFI DISCONNECTED” will appear on the LCD display whenever the connection changes which will be managed via the Zephyr Connect app.

Automatic Delay Off

- ▶ While the fan is on, press and hold  for 3 seconds to enable the delay off timer. The fan will change to speed 1, the timer display will illuminate, the LCD display will show “AUTOMATIC DELAY OFF”, and the timer will begin counting down from 10 minutes. After the timer reaches 0, the fan and lights will power off.
- ▶ The automatic delay off function timer begins at 10 minutes by default. The Zephyr Connect app provides the options for either 5 or 10 minutes.

CleanAir

- ▶ When the fan is off, press and hold  and  simultaneously for 3 seconds to enable or disable the CleanAir function. The LCD display will show “CLEAN AIR ENABLED” or “CLEAN AIR DISABLED”.
- ▶ When enabled, the fan will turn on speed 1 every 4 hours for 10 minutes. While the fan is running, the LCD display will show “CLEAN AIR ACTIVE” and the CleanAir icon will illuminate.

Features & Controls

Proximity Controls



ACT™ Verification

- ▶ Airflow Control Technology (ACT™) allows the installer to set the maximum fan CFM to align with local codes and regulations. When the fan is off, press and hold  for 3 seconds to display ACT™ status.
- ▶ ACT 290 = 3 speeds, ACT 390 = 4 speeds, ACT 590 = 5 speeds.

Grease Filter Clean Reminder

- ▶ After 60 hours of fan use, the notification bell icon will illuminate. When the bell is tapped, the LCD display will cycle between showing “CLEAN GREASE FILTERS” and then “HOLD DOWN TO RESET” every 2 seconds. If no action is taken for 30 seconds, the display turns off and the notification bell icon will remain illuminated.
 - ▶ To hold down and reset, press and hold the fan decrease button for 3 seconds to reset. The Zephyr Connect app provides the option to reset the reminder.

Recirculating Mode - Charcoal Filter Replacement Reminder

- ▶ Hold  and  for 3 seconds to enable or disable recirculating mode which will remind you to replace the charcoal filter. The LCD display will show “RECIRCULATING ENABLED” to enable and “RECIRCULATING DISABLE” to disable for 2 seconds.
- ▶ After 200 hours of fan use, the notification bell icon will illuminate. When the bell is tapped, the LCD display will cycle between showing “REPLACE CHARCOAL FLTR” and “HOLD UP TO RESET” every 2 seconds. If no action is taken for 30 seconds, the display turns off and the notification bell will remain illuminated.
 - ▶ To hold up and reset, press and hold the fan increase button for 3 seconds to reset. The Zephyr Connect app provides the option to reset the reminder.

Remote Control Pairing Mode

- ▶ Hold  for 3 seconds to enable remote control pairing mode. Once pairing mode is enabled, the LCD display will illuminate “REMOTE PAIRING”. Press a button on the remote control to synchronize it with the hood.

Zephyr Connect

Your range hood is compatible with our Zephyr Connect app. All you need is a WiFi connection with access to the Internet that can reach the location of your range hood. Zephyr Connect allows you to control your range hood from anywhere using a mobile device or your Amazon Alexa or Google Home smart speaker. Zephyr Connect also includes real time diagnostics and provides you with important product information.

The Zephyr Connect app is available on iOS devices using iOS 11.0 or later or Android devices using Android version 8 or later. Visit the Apple App Store or Google Play Store for more information.

If your range hood is not connected to WiFi, the functionality will operate similarly to a typical range hood without WiFi connectivity.

Please review the included Zephyr Connect Quick Start Guide for more information.

If you have connected your hood with either Amazon Alexa or Google Home smart speakers, you now have voice control capabilities. The list of commands for Amazon Alexa and Google Home are on the next page.

NOTE: Amazon Alexa and Google Home cannot support the voice commands in French.



Zephyr Connect

Control Type	Amazon Alexa Voice Commands	Description
Power	Alexa, turn on [Hood Name]	Turn on range hood power
	Alexa, turn off [Hood Name]	Turn off range hood power
Fan	Alexa, increase [Hood Name] Fan Speed	Increase fan speed on range hood
	Alexa, decrease [Hood Name] Fan Speed	Decrease fan speed on range hood
	Alexa, set [Hood Name] Fan Speed to [1-6]	Set range hood to specific fan speed
	Alexa, set [Hood Name] Fan Speed to Maximum	Set fan speed to 6 on range hood
	Alexa, set [Hood Name] Fan Speed to Minimum	Set fan speed to 1 on range hood
Light	Alexa, turn on [Hood Name] Light	Turn on the light on range hood
	Alexa, turn off [Hood Name] Light	Turn off the light on range hood
	Alexa, increase [Hood Name] Light(s)	Increase light level on range hood
	Alexa, decrease [Hood Name] Light(s)	Decrease light level on range hood
	Alexa, set [Hood Name] Light(s) to High	Set light level to High on range hood
	Alexa, set [Hood Name] Light(s) to Bright	Set light level to High on range hood
	Alexa, set [Hood Name] Light(s) to Low Alexa, set [Hood Name] Light(s) to Dim	Set light level to Low on range hood
Delay-Off	Alexa, set delay time to 1 minute on [Hood Name] Alexa, set delay time to 2-10 minutes on [Hood Name]	Enable delay timer for 1-10 minutes. After 1-10 minutes, the hood will be power off.
	Alexa, [Start/Enable] [Hood Name] Delay Off Timer	Enable delay off timer for 10 minutes. After 10 minutes, the hood will power off.
	Alexa, [Stop/Disable] [Hood Name] Delay Off Timer	Disable delay off timer

Control Type	Google Home Voice Command	Description
Power	Hey Google, turn on [Hood Name]	Turn on range hood power
	Hey Google, turn off [Hood Name]	Turn off range hood power
Fan	Hey Google, increase [Hood Name] speed	Increase fan speed on range hood
	Hey Google, decrease [Hood Name] speed	Decrease fan speed on range hood
	Hey Google, set [Hood Name] to speed [1-6]	Set range hood to specific fan speed
	Hey Google, set [Hood Name] to maximum speed	Set fan speed to the maximum on range hood
	Hey Google, set [Hood Name] to minimum speed	Set fan speed to the minimum on range hood
Light	Hey Google, turn on [Hood Name] light(s)	Turn on the light on range hood
	Hey Google, turn off [Hood Name] light(s)	Turn off the light on range hood
	Hey Google, set [Hood Name] light(s) to High Hey Google, set [Hood Name] light(s) to Bright	Set light level to High on range hood
	Hey Google, set [Hood Name] light(s) to Low Hey Google, set [Hood Name] light(s) to Dim	Set light level to Low on range hood
	Hey Google, set [Hood Name] light(s) to 1-3	Set range hood to specific light level
	Hey Google, Run [Hood Name] for 1-10 minutes	Enable delay timer for 1-10 minutes. After 1-10 minutes, the hood will be power off.
	Hey Google, Start 1-10 minute timer on [Hood Name]	Enable delay timer for 1-10 minutes. After 1-10 minutes, the hood will be power off.
Delay-Off	Hey Google, Stop [Hood Name] timer	Disable delay timer
	Hey Google, Cancel [Hood Name] timer	Disable delay timer

Optional RF Remote Control

To order the RF remote control, the part number is 14000005. The blue antenna wire needs to be extended for optimal signal. Unwrap the antenna wire and position it behind the duct cover. It does not need to be secured.

FCC Caution

To assure continued compliance, any changes or modifications not expressly approved by the party responsible for compliance could void the user's authority to operate this equipment. (Example - use only shielded interface cables when connecting to computer or peripheral device. This device complies with Part 15 of the FCC Rules. Operation is subject to the following two conditions. (1) This device may not cause harmful interference, and (2) This device must accept any interference received, including interference that may cause undesired operation.

Synchronization

To create a unique link between your hood and remote control please follow these steps.

1. With hood off, press and hold ⚙️ on the hood until the controls display "REMOTE PAIRING".
2. Press a button on the remote, and the remote control will be synchronized with the hood.

RF Remote Control Functions

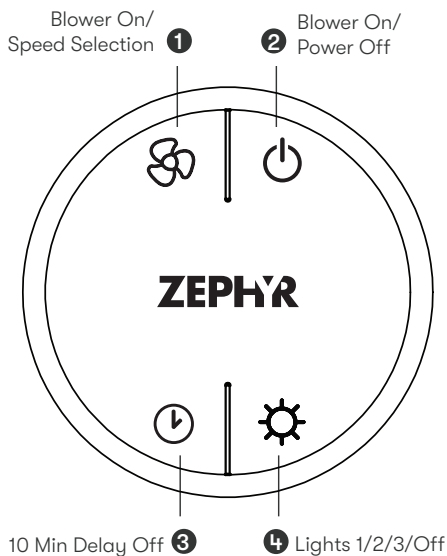

① Blower On / Speed Selection

Press ⚙️ to power on blower and cycle through all six blower speeds.

② Blower On / Power Off

By pressing ⏻, the blowers will power on at the last speed setting. Press ⏻ again and the entire hood will power off, including lights.

③ Delay Off

By pressing 🕒, the blower and lights will enter Automatic Delay Off mode. The clock icon will illuminate and the controls will display "AUTOMATIC DELAY OFF". The blower will change to speed 1 and a 10 minute timer will begin counting down.

④ Lights 1/2/3/Off

Switch between light levels by pressing ⚙️. Turn off the lights by cycling through the different light levels.

Features & Controls

Optional RF Remote Control

RF Remote Features

The RF remote control is equipped with a magnet on the back for easy storage. The remote may be placed on any magnetic surface such as a refrigerator or the Zephyr remote holder, FIG. D. The remote holder can be inserted into a standard electrical outlet for easy storage. Note: The remote holder does not charge the RF remote.

Maximum remote control communication distance is 15 feet from the liner.

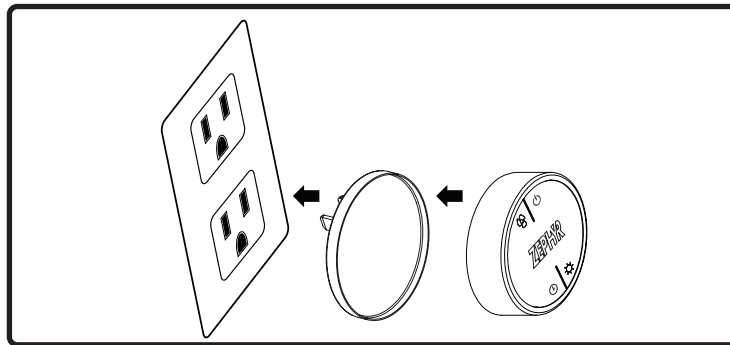

FIG. D

RF Remote Maintenance

Clean the remote control using non abrasive detergents.

Follow instructions below for replacing battery. Using a small flat head screwdriver, raise the cover of the battery door (A) in order to access the battery compartment. FIG. E.

Remove the battery and replace with battery type A23 12V. Negative end of battery should face the spring inside the remote.

Re-install battery door and recycle old battery.

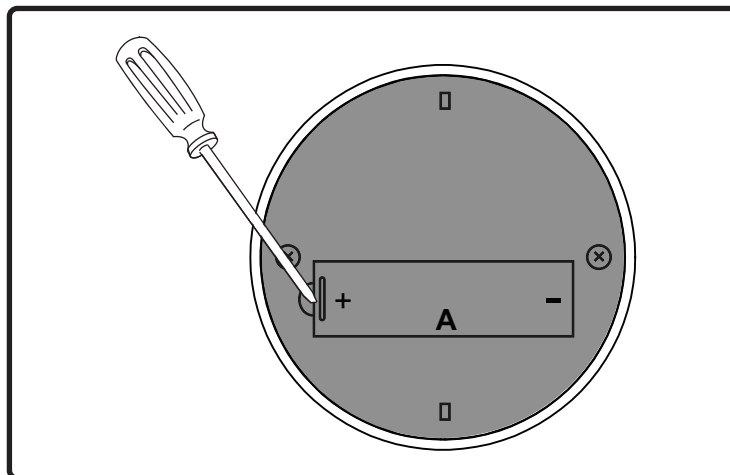

FIG. E

Hood & Filter Cleaning

Surface Maintenance

- ▶ Do not use corrosive detergents, abrasive detergents or oven cleaners.
- ▶ Do not use any product containing chlorine bleach or any product containing chloride.
- ▶ Do not use steel wool or abrasive scrubbing pads which will scratch and damage surface.

Cleaning Stainless Steel

Clean periodically with warm soapy water and clean cotton cloth or micro fiber cloth. Always rub in the direction of the stainless steel grain. To remove heavier grease build up use a liquid degreaser detergent.

After cleaning use a non-abrasive stainless steel polish/cleaners, to polish and buff out the stainless luster and grain. Always scrub lightly, with clean cotton cloth or micro fiber cloth and buff in the direction of the stainless steel grain.

Cleaning the Grease Filters

The grease filters are intended to trap residue and grease from cooking. Although the filters should never need replacing, they are required to be cleaned every 30 days or more often depending on cooking habits.

Grease filters may be placed in dishwasher at low heat or soaked in hot soapy water. Dry filters and re-install before using hood.

Maintenance

Removing Hybrid Baffle Filters (FIG. F):

1. Pull on latch to disengage filter.
2. Pull down on filter handle to remove filter.

Replacing Hybrid Baffle Filters

Hood Model	Part Number	Qty. to Order
ZVE-E30DS	50210041	2
ZVE-E36DS	50210041	2
ZVE-E42DS	50210041	2

To order parts, visit us online at <http://store.zephyronline.com>.

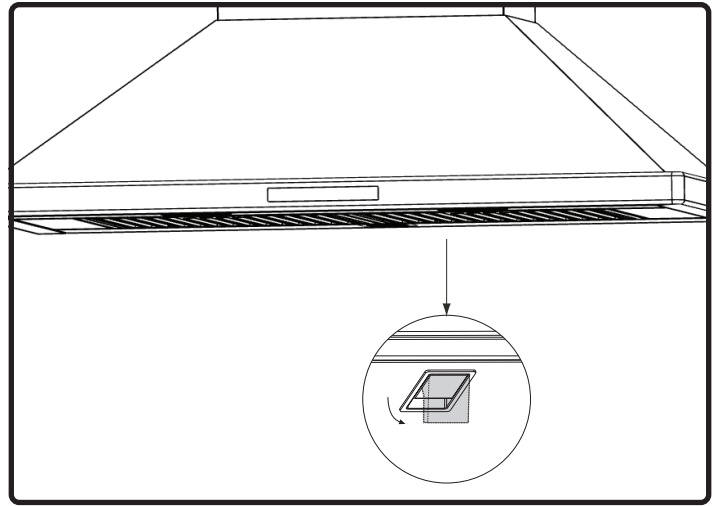

FIG. F

LumiLight LED

In the unlikely event that your LumiLight LED fails, please contact Zephyr to order replacement parts. See the list of parts and accessories page for part numbers and contact information.

LED Removal (FIG. G):

1. Remove hybrid baffle filters.
2. (If applicable) Remove both spacer panels by 2 screws for each spacer panel.
3. Remove light panel by 2 screws.
4. Disconnect LED light quick connector.
5. Push in the two side clips on the ends of the LED light.
6. Push LED light through the light panel opening.

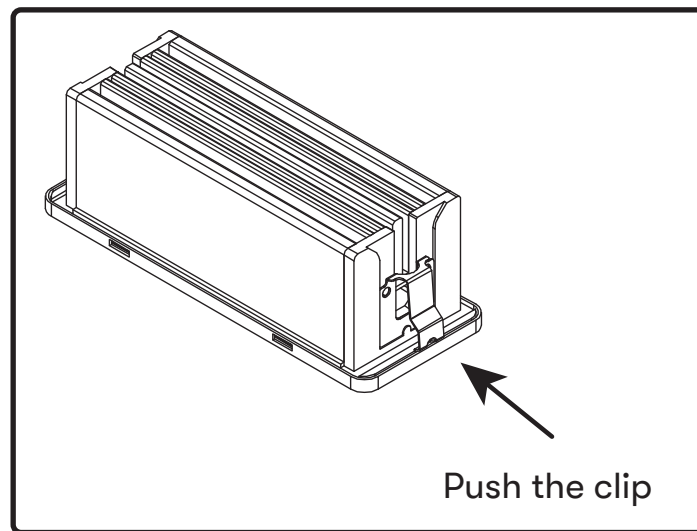

FIG. G

Airflow Control Technology (ACT™)

Some local codes limit the maximum amount of CFM a range hood can move. ACT™ allows you to control the maximum blower CFM of select Zephyr Ventilation range hoods without the need for expensive make up air kits. ACT™ enables the installer to easily set the maximum blower speed to one of three most commonly specified CFM levels; 590, 390, or 290 CFM. The usage of ACT™ may not be necessary for your installation. Please check your local codes for CFM restrictions.



CAUTION



Hood must be disconnected from the main power prior to performing the conversion instructions listed below. Failure to do so could result in personal injury or damage to the product.



CAUTION



After re-positioning the jumper and powering on the hood, the CFM cannot be changed again.

Enabling ACT™

To enable ACT™:

1. Before hood installation, gain access to PC board by following the steps shown on FIG. H.
2. Change plastic jumper positioning as shown in FIG. I to set the desired maximum blower CFM.
3. Re-install PC board and continue with hood installation.
4. Remove the appropriate foil CFM sticker included with the hood literature and place inside the hood body below the wiring diagram or in another clearly visible location.

To verify if your installer enabled ACT™:

1. With hood off, hold the On/Off button for three seconds. The Display will show if ACT™ is disabled and set to the maximum CFM or if ACT™ is enabled and set to one of the restricted maximum CFM levels of 590, 390 or 290.
2. There should also be a foil label located inside the hood body near the wiring diagram that indicates the blower CFM.

Enabling ACT™

1. PC board is located on top of motor housing.
2. Unscrew 4 screws and remove PC board from component box.

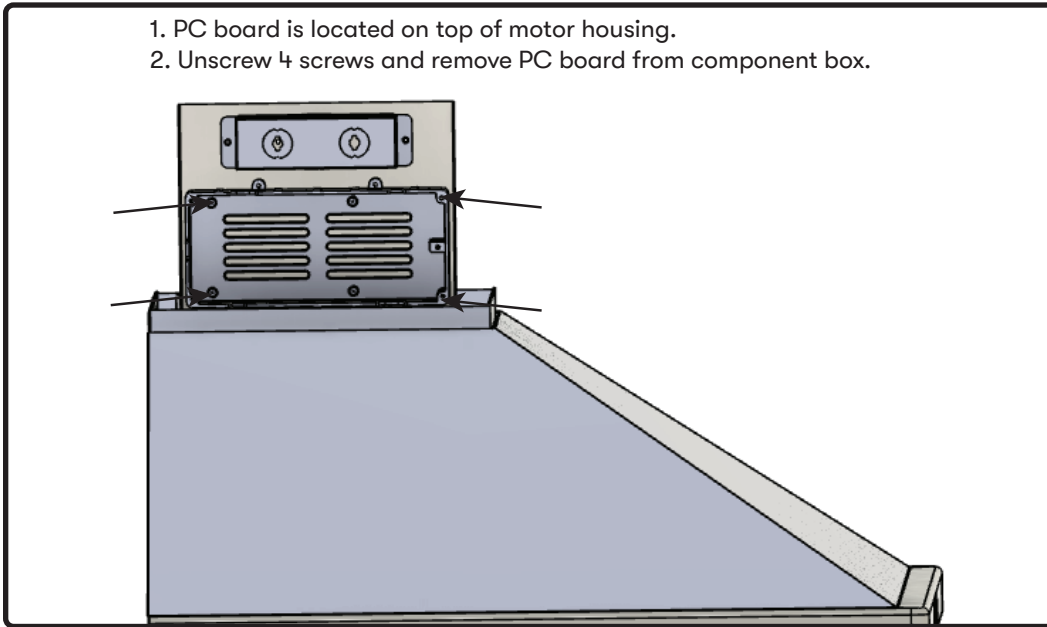

FIG. H

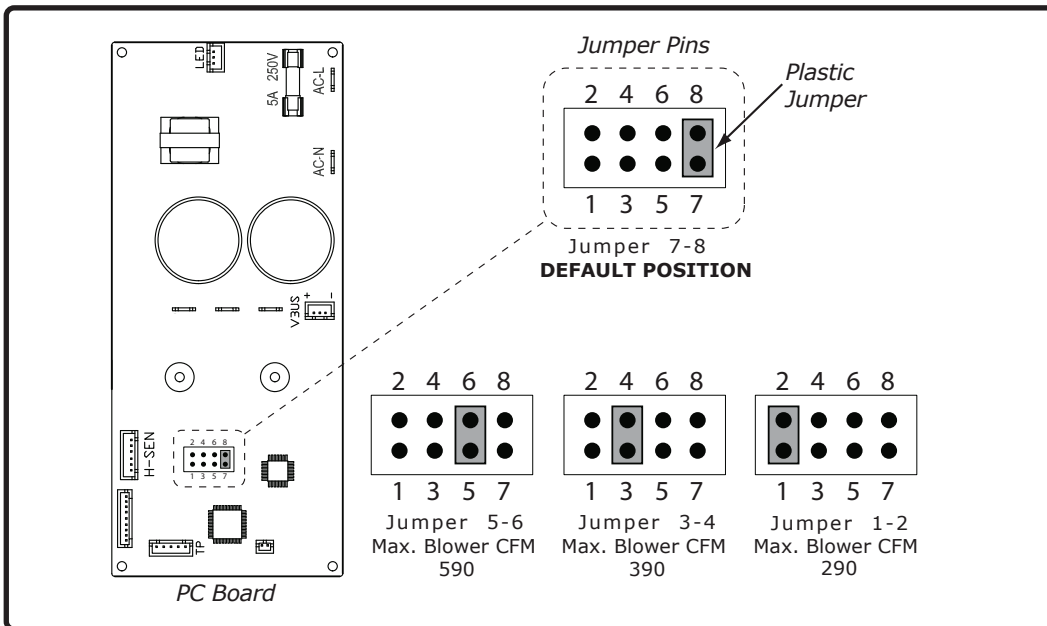
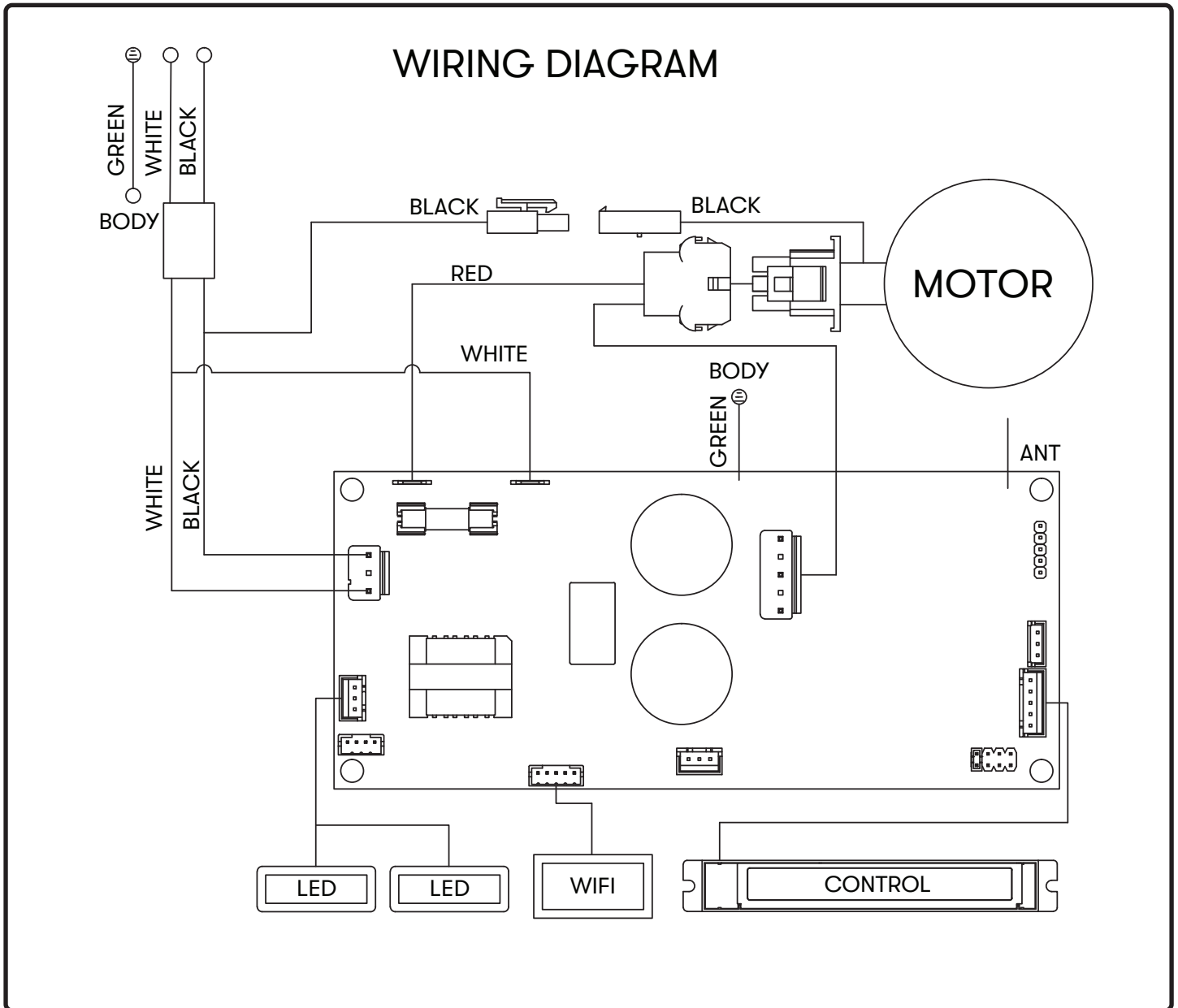



FIG. I



Troubleshooting

Possible Problem	Possible Cause	Solutions
After installation, the unit doesn't work.	The power source is not turned ON.	Make sure the circuit breaker and the unit's power is ON.
	The power line and the cable locking connector is not connecting properly.	Check the power connection with the unit is connected properly.
	The switch board or control board wirings are disconnected.	Make sure the wirings at the switch board and control board are connected properly.
	The switch board or control board is defective.	Change the switch board or control board.
	The wires on control board are loose.	Make sure the wires on the control board are connected properly.
Light works, but blower is not turning.	The blower wire is not connected.	Check all wirings from the blower to be sure all cables are properly connected.
	The thermally protected system detects if the blower is too hot to operate and shuts the blower down.	The blower will function properly after the thermally protected system cool down.
	The switch board or control board is defective.	Change defective part.
	The blower is defective, possibly seized.	Change the blower.
The unit is vibrating.	The blower is not secured in place.	Tighten the blower in place.
	Damaged blower wheel.	Replace the blower.
	The hood is not secured in place.	Check the installation of the hood.
The unit is whistling.	A filter is not in the correct position.	Adjust the filters until the whistling stops.
	The duct pipe connections are not sealed or connected properly.	Check the duct pipe connections to be sure all connections are sealed properly.
The blower is working, but the LumiLight LEDs are not.	The LumiLight LED connector is disconnected.	Connect the LumiLight LED connector.
	Defective LumiLight LED.	Change the LumiLight LED.
	The switch board or control board is defective.	Change the switch board or control board.

Possible Problem	Possible Cause	Solutions
The hood is not venting out properly.	Using the wrong size of ducting.	Change the ducting to the correct size.
	The hood might be hanging too high from the cook top.	Adjust the distance between the cook top and the bottom of the hood within 24" and 34" range.
	The wind from the opened windows or opened doors in the surrounding area are affecting the ventilation of the hood.	Close all the windows and doors to eliminate the outside wind flow.
	Blockage in the duct opening or ductwork.	Remove all the blocking from the duct work or duct opening.
The unit turns on by itself.	Remote control may be paired incorrectly.	Resynchronize the remote control to connect to a different channel
	Someone is controlling the hood via the Zephyr Connect app.	Determine who is controlling the hood with the app.
Filter is vibrating.	Filter is loose.	Adjust or change the filter.
	Spring clip is broken on the filter.	Change the spring clip.
RF Remote control does not work.	Battery is dead.	Replace battery with type A23 12v.
	Poor communication with the hood.	Remote control must be within 15 ft of hood.
	RF Remote lost communication with the hood.	Reset hood and remote by switching power off at the circuit breaker for 5 minutes. Place remote on counter top near the hood and switch the circuit breaker back on.
	Blue antenna wire is not extended.	Extend the blue antenna wire behind the light panel.
The range hood and user's device won't pair via Bluetooth®.	The user's phone does not have Bluetooth® enabled.	Enable Bluetooth® on the user's phone.
	The user's phone may be out of range.	Move closer towards the range hood.
	User hasn't inputted the Bluetooth® code to successfully pair.	Enter the pairing code, 123456.
	Range hood is not in Bluetooth® pairing mode.	Hold  and  simultaneously for 5 seconds to put the hood into pairing mode.
	There are multiple errors preventing the user's phone from pairing with the range hood.	Restart the user's phone and try again.

Troubleshooting

Possible Problem	Possible Cause	Solutions
The range hood won't connect to Wi-Fi.	The user's router or modem is turned off.	Turn on the router or modem.
	The user's router is connected to a 5 GHz wireless frequency.	Connect to the 2.4 GHz band and attempt to reconnect.
	The user's coaxial cables are loose.	Tighten the coaxial cables connecting to the router or modem.
	The Wi-Fi on the user's phone is disabled.	Enable Wi-Fi on the phone.
	User is connecting to the wrong Wi-Fi network.	Verify that the correct Wi-Fi network is being connected to. The default Wi-Fi network name/SSID can be found on the router.
	The range hood is not in range of the Wi-Fi connection.	Move the router and modem closer to the range hood to increase connection strength.
	There are obstacles obstructing the Wi-Fi signal strength.	Move the router and modem closer to the range hood or move objects that are directly blocking the pathway to the range hood. Walls may reduce signal strength.
User cannot change Wi-Fi connections.	The range hood and user's phone have already connected.	Enter Bluetooth® settings and forget the device to reset the process on the phone.
Cannot bind the hood to my Zephyr Connect account.	Only one Zephyr Connect account can be bound to the hood.	Log in using the Zephyr Connect account that is already bound to the hood. Multiple devices can login using the same account.
Zephyr Connect app won't register user inputs.	Wi-Fi is unstable and the range hood may have disconnected.	Ensure the router and modem are both turned on. Allow the range hood to reconnect.
	Range hood is experiencing difficulties connecting to the user's phone.	Check on the Wi-Fi connection and restart the application.
Zephyr Connect app stuck on "Loading".	Wi-Fi is unstable and the range hood may have disconnected.	Ensure the router and modem are both turned on. Allow the range hood to reconnect.
	Range hood is experiencing difficulties connecting to the user's phone.	Check on the Wi-Fi connection and restart the application.

Description	Part Number
Replacement Parts	
LumiLight LED, 6W	Z0B0047
Hybrid Baffle Filter	50210041
Optional Accessories	
RF Remote Control	14000005
Recirculating Kit	ZRC-03VE
Replacement Charcoal Filter (each)	Z0F-C005
Duct Cover Extension	Z1C-01VE

To order parts, visit us online at <http://store.zephyronline.com>.

TO OBTAIN SERVICE UNDER WARRANTY OR FOR ANY SERVICE RELATED QUESTIONS**United States Customers please call: 1-888-880-8368 or contact us at: zephyronline.com/contact****Canada Customers please call: 1-800-361-0799 or Email: service@distinctive-online.com**

Zephyr Ventilation, LLC (referred to herein as “we” or “us”) warrants to the original consumer purchaser (referred to herein as “you” or “your”) of Zephyr products (the “Products”) that such Products will be free from defects in materials or workmanship as follows:

Three Year Limited Warranty for Parts: For three years from the date of your original purchase of the Products, we will provide, free of charge, Products or parts (including LED light bulbs, if applicable) to replace those that failed due to manufacturing defects subject to the exclusions and limitations below. We may choose, in our sole discretion, to repair or replace parts before we elect to replace the Products.

One Year Limited Warranty for Labor: For one year from the date of your original purchase of the Products, we will provide, free of charge, the labor cost associated with repairing the Products or parts to replace those that failed due to manufacturing defects subject to the exclusions and limitations below. After the first year from the date of your original purchase, you are responsible for all labor costs associated with this warranty.

Warranty Exclusions: This warranty covers only repair or replacement, at our option, of defective Products or parts and does not cover any other costs related to the Products including but not limited to: (a) normal maintenance and service required for the Products and consumable parts such as fluorescent, incandescent or halogen light bulbs, mesh and charcoal filters and fuses; (b) any Products or parts which have been subject to freight damage, misuse, negligence, accident, faulty installation or installation contrary to recommended installation instructions, improper maintenance or repair (other than by us); (c) commercial or government use of the Products or use otherwise inconsistent with its intended purpose; (d) natural wear of the finish of the Products or wear caused by improper maintenance, use of corrosive and abrasive cleaning products, pads, and oven cleaner products; (e) chips, dents or cracks caused by abuse or misuse of the Products; (f) service trips to your home to teach you how to use the Products; (g) damage to the Products caused by accident, fire, floods, acts of God; or (h) Custom installations or alterations that impact serviceability of the Products. If you are outside our service area, additional charges may apply for shipping costs for warranty repair at our designated service locations and for the travel cost to have a service technician come to your home to repair, remove or reinstall the Products. After the first year from the date of your original purchase, you are also responsible for all labor costs associated with this warranty. All Products must be installed by a qualified professional installer to be eligible for warranty repairs or service.

Limitations of Warranty. OUR OBLIGATION TO REPAIR OR REPLACE, AT OUR OPTION, SHALL BE YOUR SOLE AND EXCLUSIVE REMEDY UNDER THIS WARRANTY. WE SHALL NOT BE LIABLE FOR INCIDENTAL, CONSEQUENTIAL OR SPECIAL DAMAGES ARISING OUT OF OR IN CONNECTION WITH THE USE OR PERFORMANCE OF THE PRODUCTS. THE EXPRESS WARRANTIES IN THE PRECEDING SECTION ARE EXCLUSIVE AND IN LIEU OF ALL OTHER EXPRESS WARRANTIES. WE HEREBY DISCLAIM AND EXCLUDE ALL OTHER EXPRESS WARRANTIES FOR THE PRODUCTS, AND DISCLAIM AND EXCLUDE ALL WARRANTIES IMPLIED BY LAW, INCLUDING THOSE OF MERCHANTABILITY AND FITNESS FOR A PARTICULAR PURPOSE.

Some states or provinces do not allow limitations on the duration of an implied warranty or the exclusion or limitation of incidental or consequential damages, so the above limitations or exclusions may not apply to you. To the extent that applicable law prohibits the exclusion of implied warranties, the duration of any applicable implied warranty is limited to the same three-year and one-year periods described above if permitted by applicable law. Any oral or written description of the Products is for the sole purpose of identifying the Products and shall not be construed as an express warranty. Prior to using, implementing or permitting use of the Products, you shall determine the suitability of the Products for the intended use, and you shall assume all risk and liability whatsoever in connection with such determination. We reserve the right to use functionally equivalent refurbished or reconditioned parts or Products as warranty replacements or as part of warranty service. This warranty is not transferable from the original purchaser and only applies to the consumer residence where the Product was originally installed located in the United States and Canada. This warranty is not extended to resellers.

To Obtain Service Under Limited Warranty: To qualify for warranty service, you must: (a) notify us at the address or telephone number stated below within 60 days of the discovery of the defect; (b) give the model number and serial number; and (c) describe the nature of any defect in the Product or part. At the time of the request for warranty service, you must present evidence of your proof of purchase and proof of the original purchase date. If we determine that the warranty exclusions listed above apply or if you fail to provide the necessary documentation to obtain service, you will be responsible for all shipping, travel, labor and other costs related to the services. This warranty is not extended or restarted upon warranty repair or replacements.

Please check our website for any additional Product information, www.zephyronline.com

Zephyr, 2277 Harbor Bay Parkway, Alameda, CA 94502

Product Registration

Congratulations on the purchase of your Zephyr product! Please take a moment to register your new Zephyr product at www.zephyronline.com/registration

IT'S IMPORTANT

Prompt registration helps in more ways than one.

- Ensures warranty coverage should you need service.
- Ownership verification for insurance purposes.
- Notification of product changes or recalls.



Zephyr Ventilation | 2277 Harbor Bay Pkwy. | Alameda, CA 94502 | 1.888.880.8368