



FF1142PL



66.75" x 23.5" x 25.5" (H x W x D)

ENERGY STAR-certified 24" wide 11.5 cu.ft. top mount frost-free refrigerator-freezer in a stainless steel look

Highlights:

ENERGY STAR-qualified performance ensures annual savings

Over 11 cu.ft. of interior storage in a slim-fitting footprint

True frost-free operation saves you maintenance by preventing icy buildup

Product Features:

24" Wide Top Mount Refrigerator-Freezer	Slim-fitting design ideal for smaller kitchens
ENERGY STAR-certified	Rated by the DOE to perform with more efficiency than federal standards require, saving your unit energy and you on higher utility costs
Frost-free operation	No-frost convenience for reduced user maintenance
Thin-line design	Limited space is no problem for our thin-line models, designed specifically for those hard-to-fit spots
Large capacity	11.5 cu.ft. interior offers generous storage in a slim fit
Stainless steel look	Doors offer the look of stainless steel complete with a vertical grain, but the easier cleanability of a fingerprint-resistant steel finish
Adjustable glass shelves	Rearrange your refrigerator space to accommodate all shapes and sizes or remove shelves for a simple clean-up
Crisper drawer	Get the longest life and best taste out of produce by storing it in a convenient slide drawer
Door storage	Multiple door shelves in both the refrigerator and freezer compartments offer convenient storage for condiments and bottles



FF1142PL Specifications:

Overview	
Nominal Width	24.0" (61 cm)
Nominal Depth	26.0" (66 cm)
Nominal Height	67.0" (170 cm)
Height of Cabinet	66.75" (170 cm)
Width	23.5" (60 cm)
Width with Door Open	24.63" (63 cm)
Depth	25.5" (65 cm)
Depth with door at 90°	50.0" (127 cm)
Capacity	11.6 cu.ft. (328 L)
Defrost Type	Frost-Free
Door	Stainless Look
Cabinet	Gray
US Electrical Safety	CSA
Canadian Electrical Safety	CSA-C
Energy Usage/Year	308.0kWh/year
Amps	2.5
Voltage/Frequency	115 V AC/60 Hz
Weight	121.0 lbs. (55 kg)
Parts & Labor Warranty	1 Year
Compressor Warranty	5 Years
UPC	761101103600
Refrigerator-Freezer	
Door Swing	RHD
Reversible	Yes
Adjustable Shelves	Yes
Crisper Qty	1
Crisper Finish	Transparent
Crisper Cover	Plastic
Interior Light	Yes
Refrigerator - Interior Height	40.63" (103 cm)
Refrigerator - Interior Width	20.5" (52 cm)
Refrigerator - Interior Depth	19.5" (50 cm)
Refrigerator - Shelf Type	Glass
Refrigerator - Shelf Qty	3
Refrigerator - Full Door Shelves	3

Freezer - Interior Height	16.75" (43 cm)
Freezer - Interior Width	17.5" (44 cm)
Freezer - Interior Depth	15.75" (40 cm)
Freezer - Shelf Type	Glass
Freezer - Full Door Shelves	2
Thermostat Type	Dial
Refrigerant Type	R600a
Refrigerant Amount	1.2 oz.
High Side PSI	250.0
Low Side PSI	88.0
Level Legs	2
Interior Height - Drawer 1	9.5" (24 cm)
Interior Width - Drawer 1	20.5" (52 cm)
Interior Depth - Drawer 1	16.0" (41 cm)
Compressor Step Height	9.5" (24 cm)
Compressor Step Width	20.5" (52 cm)
Compressor Step Depth	6.0" (15 cm)
Sound Level	32.6 dB

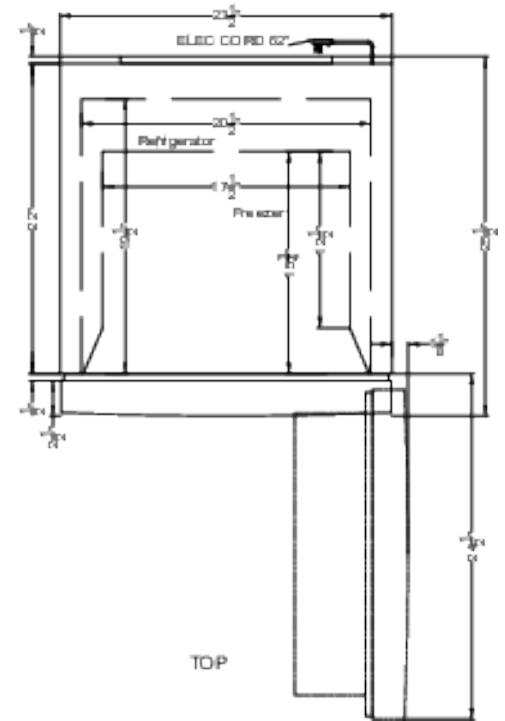

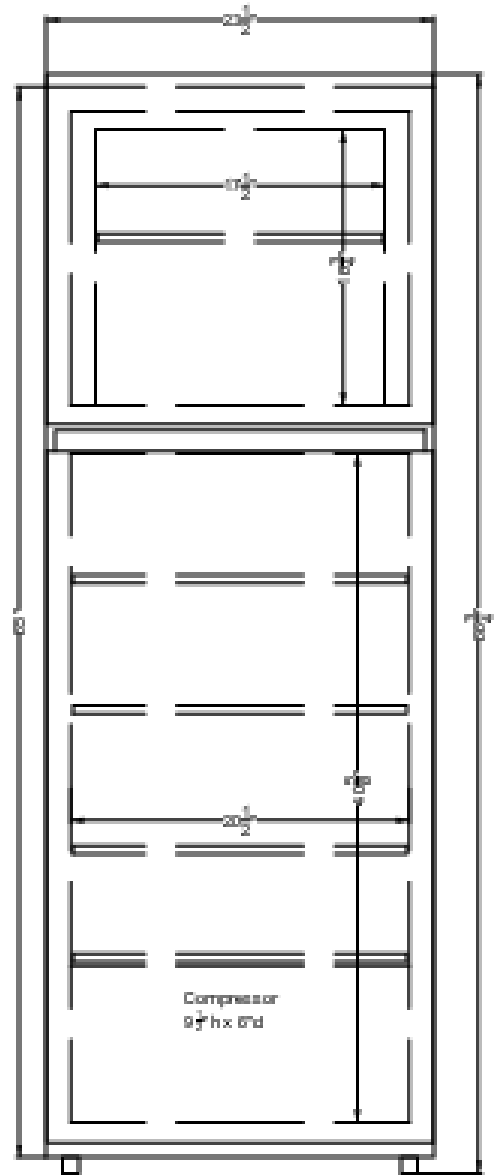

FRONT